



# BRAISING PANS

## TILTING SKILLET ELECTRIC MODELS BPM-E

Braising pan shall be a Groen electric heated manual tilting BPM Series (specify 15, 30 or 40 gallon, Classic (C), Advanced (A) or Cook2Temp™ (C2T) controls) model 8" (15E) or 10" (30E, 40E) deep pan body with 3" radius corners, 5/8" thick stainless steel clad cooking surface mounted on open leg stand with height-adjustable bullet feet. CookTemp models also come with a probe.

### AVAILABLE MODELS:

#### CLASSIC CONTROLS:

- BPM-15EC (15 GALLON)
- BPM-30EC (30 GALLON)
- BPM-40EC (40 GALLON)

#### ADVANCED CONTROLS:

- BPM-15EA (15 GALLON)
- BPM-30EA (30 GALLON)
- BPM-40EA (40 GALLON)

#### COOK2TEMP CONTROLS:

- BPM-15EC2T (15 GALLON)
- BPM-30EC2T (30 GALLON)
- BPM-40EC2T (40 GALLON)

**CONSTRUCTION:** The pan body shall be of type 304 stainless steel, solid one-piece welded heavy-duty construction, with 8" (15E) or 10" (30E, 40E) pan depth. All exposed surfaces shall be stainless steel. The cooking surface is a heavy 5/8" thick stainless steel clad plate fitted with flat bar electric heating elements, ensuring efficient heat transfer over the entire cooking surface. The heavy plate prevents warping or distortion. Controls and tilt mechanism are mounted in a stainless steel water resistant IPX6-rated housing, on right side of the pan body. Braising pan shall come standard with mounting bracket for either right-side, left-side or right-rear faucet mounting. Graduated fill-level marks in both gallons and liters are standard.

**FINISH:** Interior of braising pan shall be polished to a 100 emery grit finish on C/A models, 180 emery grit on C2T models. Exterior of braising pan shall have a #3 finish, ensuring maximum ease in cleaning and maintaining appearance.

**SANITATION & NSF LISTING:** Braising pan shall be designed and constructed to be NSF-listed, meeting all known health department and sanitation codes. True open leg tubular stand design and 3" radius pan interior make cleaning easier.

**UL LISTING:** Braising pan shall be UL- and cUL- listed.

**MANUAL TILT:** The braising pan shall have a smooth-action, quick-tilting body with manual crank and worm-and-gear tilt mechanism, which provides precise control during pouring of pan contents. Pan body shall tilt to vertical in 24 turns and past vertical to assist in cleaning.

**CONTROLS:** All controls to be located in a right-front mounted water resistant (IPX6 rated) enclosure:  
**Classic -C Models** include: Power ON-OFF switch with indicator light, temperature control knob with 175 to 400°F (79 to 204°C) range increments and HEAT(ing) indicator light;  
**Advanced -A Models** include: Same control features as Classic models with the addition of temperature and time set knob (175 to 400°F/79 to 204°C range), LED display of set temperature or cook time, buttons for reset of Low Temp and High Temp presets, MANUAL mode button for knob-setting of pan temperature, and TIMER-set button with indicator light;  
**Cook2Temp -C2T Models** include: Same control features as Classic and Advanced models with the addition of Auto C2T and Manual C2T buttons with core probe connection port, MANUAL mode button for knob-setting of pan temperature for manual cooking and manual C2T cooking.

**PERFORMANCE/FEATURES:** Braising pan shall be equipped with controls that allow operation at 7-degree angle to facilitate griddling. Braising pan shall be thermostatically-controlled for automatic shut-off when desired temperature is reached and automatic power ON when temperature falls below desired setting. Braising pan to have high limit thermostat as safety feature.

**INSTALLATION:** One electrical connection required. Specify 208, 240 or 480 Volt electrical service. All units ship three-phase, and are field convertible to single-phase operation.

**ORIGIN OF MANUFACTURE:** Designed and manufactured in the United States.



PROJECT NAME:	
LOCATION:	
ITEM NO:	
QTY:	
MODEL NO:	
AIA NO:	
SIS NO:	
CSI SECTION:	11400



BPM-15EA Model shown

### OPTIONS/ACCESSORIES:

- Single pantry water faucet
- Double pantry water faucet
- Single or double pantry faucet with spray hose assembly (48" or 60")
- 2" tangent drawoff (option must be ordered with unit)
- Strainer for tangent drawoff valve
- Pouring lip strainer
- Flanged feet
- Caster kit w/restraint cable
- Steamer pan carrier (on 30 and 40 gallon models only)
- Steamer pan inserts
- Replacement core probe (on C2T models only)

### ADDITIONAL RESOURCES:

- [Request A Quote](#)
- [Sales Tools](#)
- [Find A Rep](#)

ELECTRICAL REQUIREMENTS			
REQ'D VOLTAGE	BPM-15E		Kw
	PHASE	AMPS	
208	1	37	7.7
	3	22	
240	1	32	7.7
	3	19	
440	3	9	6.4
	3	10	7.6

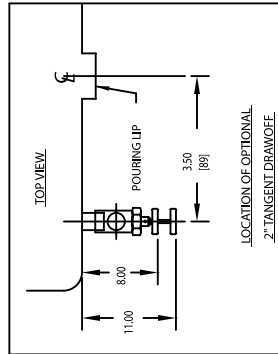

- NOTES:
1. DIMENSIONS IN BRACKETS ( ) ARE MM.
  2. BULLET FEET SUPPLIED FRONT & REAR
  3. ELECTRICAL CONNECTION: 1.75\"/>
  - 4. OTHER VOLTAGES AND PHASES ARE AVAILABLE.
  - 5. FAUCET BRACKET MAY BE INSTALLED ON LEFT OR RIGHT SIDE.
  - 6. FAUCET MAY BE INSTALLED ON FAUCET BRACKET OR ON REAR AS SHOWN.
  - 7. OPTIONAL FLANGED FEET OR CASTERS AVAILABLE
  - 8. TETHER REQUIRED WITH CASTERS TO SECURE UNIT

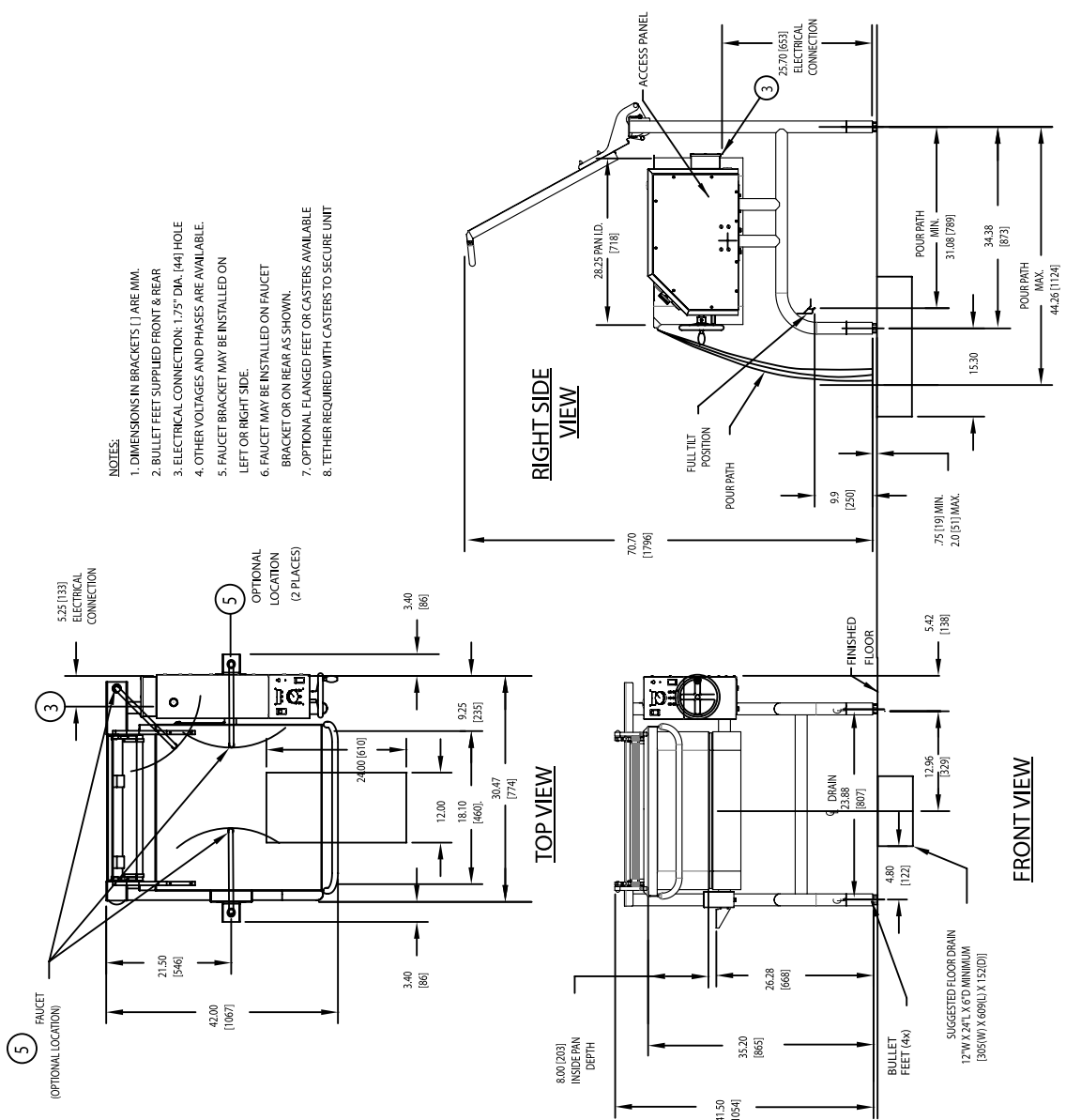

CLASSIC CONTROL



ADVANCED CONTROL



COOK2TEMP CONTROL

REQ'D VOLTAGE	ELECTRICAL REQUIREMENTS		
	BPM-30E	BPM-40E	
208	PHASE	Kw	AMPS
	1	56	74
	3	32	43
240	PHASE	Kw	AMPS
	1	48	64
	3	28	37
480	PHASE	Kw	AMPS
	3	14	11.5
	3	19	15.3

MODEL	BPM-30E		BPM-40E	
	INCH	MM	INCH	MM
DIMS. A	26.25	667	35.75	908
B	32.00	813	41.50	1054
C	38.50	984	48.00	1226
D	8.75	222	13.50	343
E	8.90	225	13.60	346
F	17.10	435	21.90	556

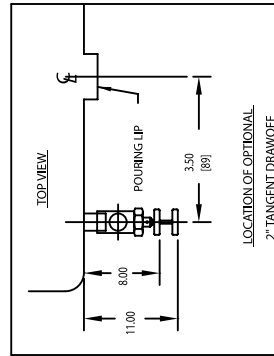

- NOTES:
1. DIMENSIONS IN BRACKETS [ ] ARE MM.
  2. BULLET FEET SUPPLIED FRONT & REAR.
  3. ELECTRICAL CONNECTION: 1.75" DIA. [44] HOLE.
  4. OTHER VOLTAGES AND PHASES ARE AVAILABLE.
  5. FAUCET BRACKET MAY BE INSTALLED ON LEFT OR RIGHT SIDE.
  6. FAUCET MAY BE INSTALLED ON FAUCET BRACKET OR ON REAR AS SHOWN.
  7. OPTIONAL FLANGED FEET OR CASTERS AVAILABLE.
  8. TETHER REQUIRED WITH CASTERS TO SECURE UNIT.

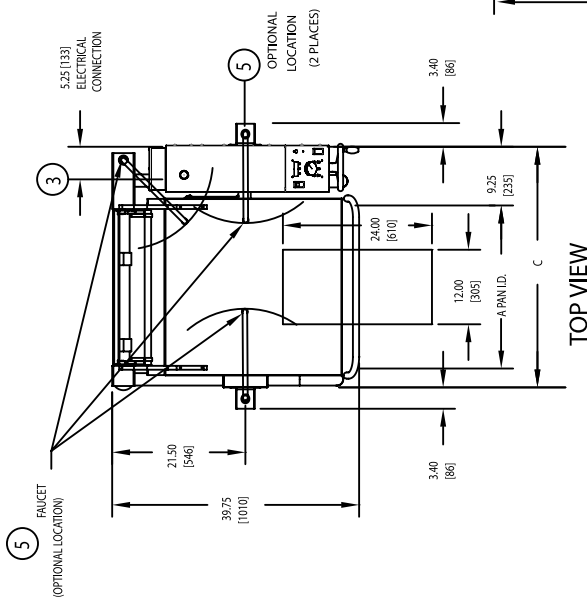

RIGHT SIDE VIEW

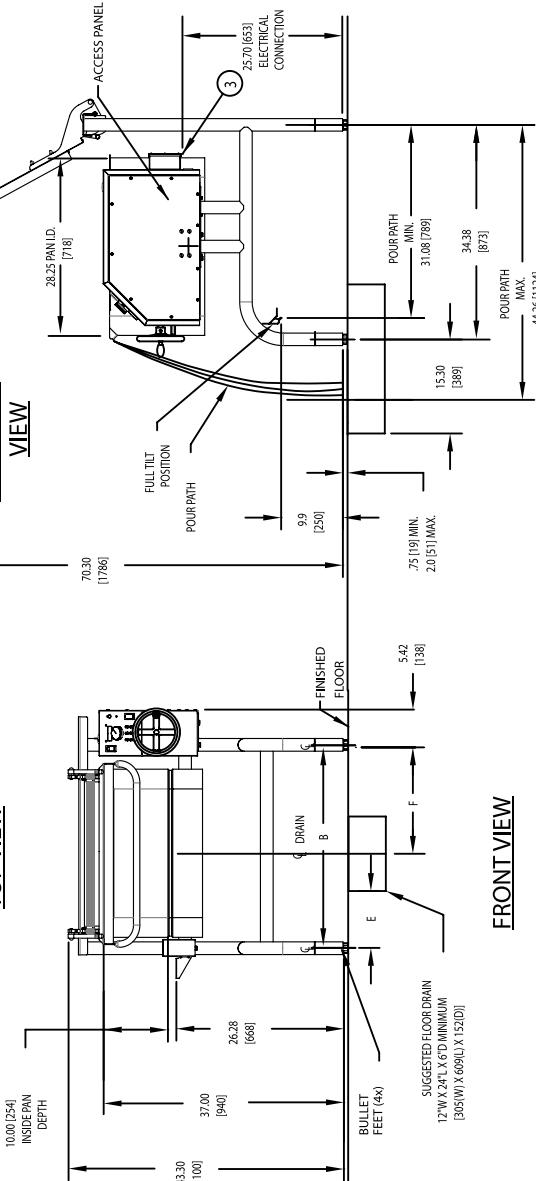

CLASSIC CONTROL



ADVANCED CONTROL



COOK2TEMP CONTROL