

DOMINATOR

E2112 Convection Oven

Key features

- Large capacity convection oven
 - 2/1 GN compatible chamber delivers even heating
- Easy to monitor cooking progress in oven
 - Internal oven light & glass panelled doors
- Wide oven temperature range of 100 - 250°C
 - Ideal to prepare a wide variety of food
- Twin oven doors with individual catches
 - Retains heat within the oven chamber
- Oven has 5 shelf positions and allows 4 shelf cooking
 - Versatile, ideal for a wide range of menu items
 - 4 anti-tilt shelves supplied

Accessories

- Oven shelf
- Factory fitted adjustable castors
- Heat resistant insulated floorpad

Similar Models

- E2112S convection oven on stand
- G2112 gas convection oven



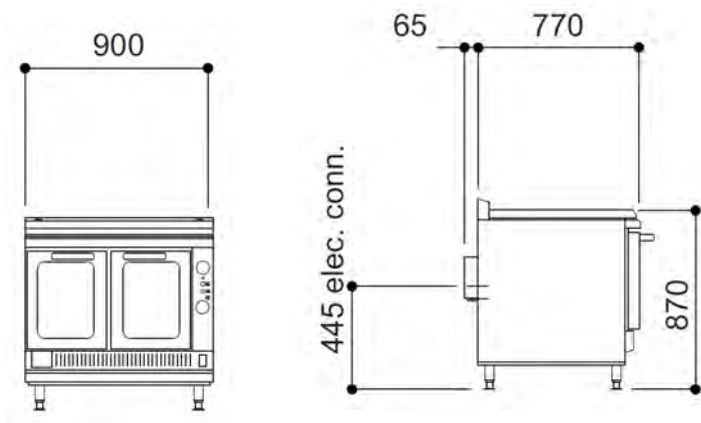

Unit on castors is 890

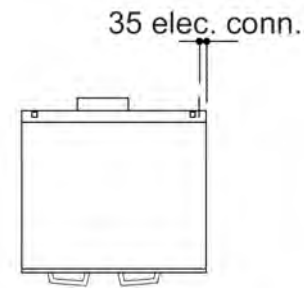

Measurements *in mm*

Specification *details*

| | | |
|------------------------------------|--------------------------|------------|
| Total rating (kW) | 11 | |
| Electrical supply voltage | 400V 3N~ or 230V~ | |
| Electrical current split (A) | L1: 12.5, L2: 12, L3: 12 | |
| Oven dimensions (w x d x h - mm) | 620 x 505 x 425 | |
| Oven shelf (w x d - mm) | 620 x 505 | |
| Gastronorm compatibility | 2/1 | |
| Weight (kg) | 193 | |
| Packed weight (kg) | 203 | |
| Packed dimensions (w x d x h - mm) | 1000 x 1000 x 1100 | |
| GTIN numbers: | On Feet | On Castors |
| | | |

Installation notes

Ventilation

Adequate ventilation, whether natural or mechanical, must be provided to supply sufficient fresh air for combustion and to allow easy removal of such products that may present risk to health. Recommendations for ventilation of appliances are given in BS5440:2 and HVCA specification DW/172. For multiple installations, requirements for individual appliances should be added together. Installation of any such system must be completed in accordance with local and/or national regulations that apply at time of commissioning.

Siting

Install range on a level, fireproof surface in a well-lit, draught free position. If floor is made of a combustible material, local fire requirements must be checked to ensure compliance. A clearance of 150mm should be observed between appliance rear and any combustible wall. Minimum vertical clearance of 1200mm should be maintained above top edge of range and 450mm above oven flues. Flue discharges vertically through hob rear grille. No direct connection of flue should be made to any mechanical extraction system or to the outside air.

