

DOMINATOR PLUS

ITEM No	DESCRIPTION	SPARES No
1	OPERATING THERMOSTAT	733700000
2	MAINS PILOT LIGHT (RED)	730962010
3	TERMINAL BLOCK	731000006
4	FUSE 2A	734243006
5	CIRCUIT PILOT LIGHT (AMBER)	730962040
6	SAFETY THERMOSTAT	733700002
7	CONTACTOR	734310440
8	SIDE ELEMENT	733700004
9	CENTRE ELEMENT	733700003
10		
11		

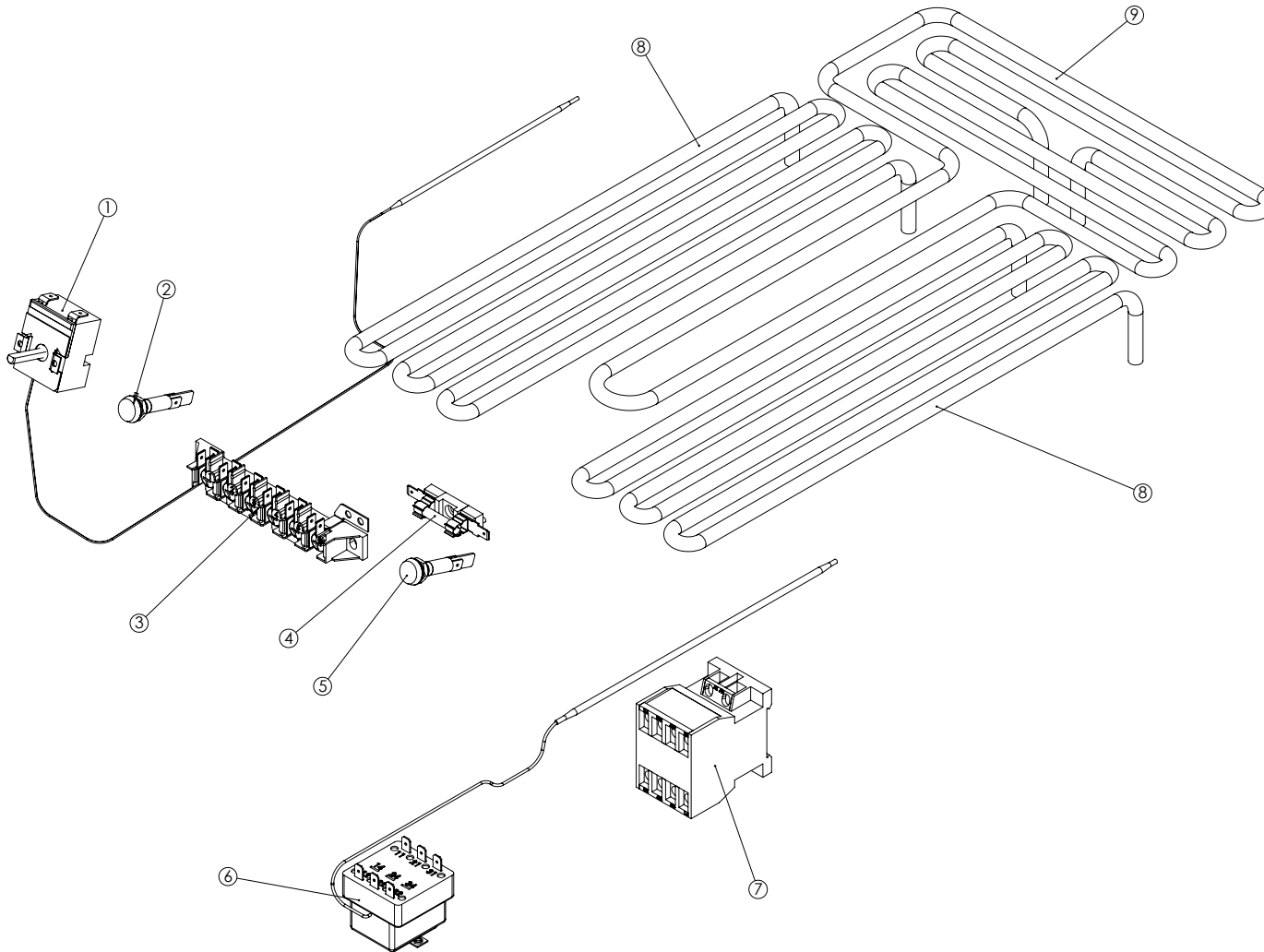

Issue	Alteration	Date	Product	Document Reference
A	Initial Issue	05/09/19	E3741	BD56051

DOMINATOR PLUS

ITEM No	DESCRIPTION	SPARES No
1	GASTRONORM TRAY	733700009
2	HANDLE	733500008
3	GASTRONORM SLIDE	733700005
4	GASTRONORM RUNNERS (PAIR)	733700006
5	GASTRONORM INSERT	733700014
6	INFILL PANEL	735800000
7	CONTROL VINYL	735800001
8	CONTROL PANEL	735800002
9	CONTROL KNOB	735800003
10	PLUG REMOVAL TOOL	733700008
11	DRAIN PLUG	733700007
12	REAR FLUE	735800004
13	ADJUSTABLE LEG (150mm)	535480067
14	FIXED CASTOR	530964340
15	SWIVEL CASTOR	535400222
16		

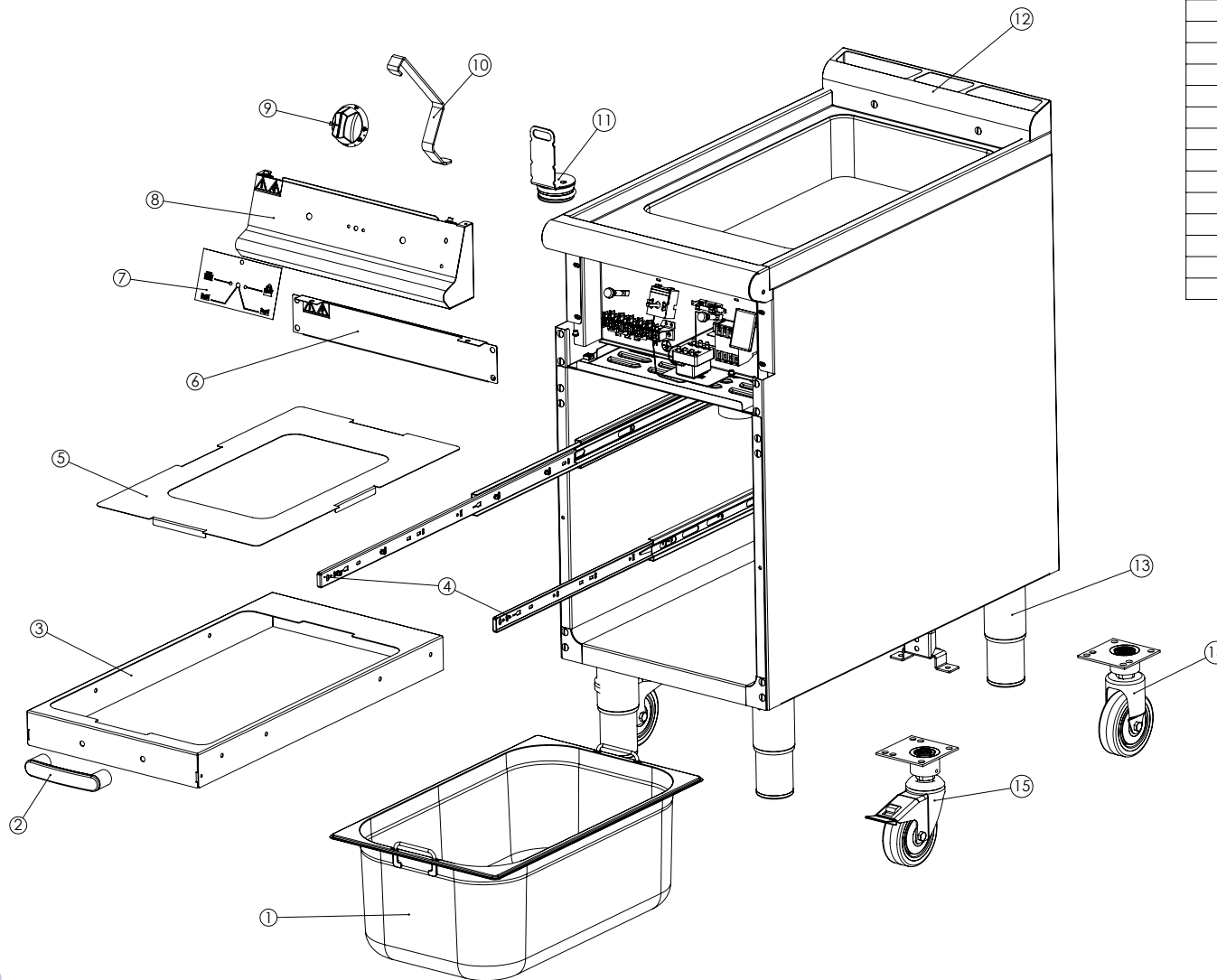

Issue	Alteration	Date	Product	Document Reference
A	Initial Issue	05/09/19	E3741	BD56052