



F900 SERIES

User, installation and servicing instructions

CHIP SCUTTLE

E9646

Read these instructions before use

DATE PURCHASED:

MODEL NUMBER:

SERIAL NUMBER:

DEALER:

SERVICE PROVIDER:

T100890

REV. 9

Dear Customer,
Thank you for choosing Falcon Foodservice Equipment.

This manual can be downloaded from www.falconfoodservice.com Or scan here



IMPORTANT: Please keep this manual for future reference.

Falcon Foodservice Equipment

HEAD OFFICE

Wallace View, Hillfoots Road,
Stirling, FK9 5PY, Scotland.
Tel: 01786 455200

PREVENTATIVE MAINTENANCE CONTRACT

To obtain maximum performance from this unit regular servicing of the appliance should be undertaken to ensure correct operation, it is functioning as intended, and safe to use. We recommend servicing in accordance with SFG20 Maintenance Schedules and as a minimum, after 2,500 hours of use, or annually, whichever comes first and that a maintenance contract be arranged with an appointed service contact. Visits may then be made at agreed intervals to carry out adjustments and repairs.

WEEE Directive Registration No. WEEE/DC0059TT/PRO



At end of appliance life, dispose of appliance and any replacement parts in a safe manner, via a licensed waste handler. Appliances are designed to be dismantled easily and recycling of all material is encouraged whenever practicable.



SYMBOLS



• SPANNER



• SCREWDRIVER



• COOKING OIL



• GREASE

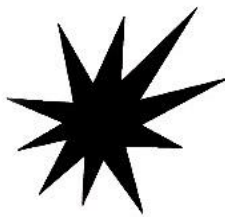

• SPARK IGNITION



• FLAME



• WARNING



• VIEWPORT

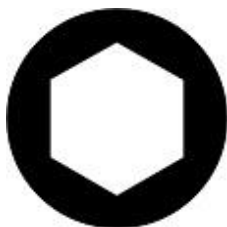

• ALLEN KEY



• IGNITER





- **This appliance may be discolored due to testing.**
- **These instructions are only valid if the country code appears on the appliance. If the code does not appear on the appliance, refer to the technical instructions for adapting the appliance to the conditions for use in that country.**
- **This appliance has been UKCA/CE marked based on compliance with the relevant Electrical and Electromagnetic Compatibility (EMC) Regulations/Directives for the voltages stated on the data plate.**
- **Installation must meet national or local regulations. Attention must be paid to: safety (installation & use) regulations, health and safety at work act, local and national building regulations, fire precautions act.**
- **To prevent shocks, all appliances must be earthed.**
- **This equipment is for professional use only and must be used by qualified persons.**
- **The installer must instruct the responsible person(s) of the correct operation and maintenance of the appliance.**
- **Unless otherwise stated, parts which have been protected by the manufacturer must not be adjusted by the installer.**
- **Take care when moving an appliance fitted with castors.**
- **The appliance must be serviced regularly by a qualified person. Service intervals should be agreed with the service provider.**
- **Check that no damage has occurred to the appliance or supply cord during transit. If damage has occurred, do not use the appliance.**
- **We recommend supplementary electrical protection with the use of a type A residual current device(RCD).**
- **Installation, periodic testing, repair and fixed wiring connections should only be undertaken by a competent electrician.**
- **Ensure supply cord is routed free from appliance to avoid damage.**

CONTENTS

1.0	APPLIANCE INFORMATION	6
2.0	OPERATION	7
2.1	COMPONENT PARTS / CONTROLS	7
2.2	USING THE APPLIANCE	8
3.0	CLEANING AND MAINTENANCE	9
4.0	SPECIFICATION	10
5.0	DIMENSIONS / CONNECTION LOCATIONS	11
6.0	INSTALLATION	12
6.1	SITING / CLEARANCES	13
6.2	SUPPLY CONNECTION	13
6.3	ELECTRICAL RATINGS	13
6.4	ASSEMBLY	14
6.5	COMMISSIONING	14
6.6	SUITING	15
7.0	SERVICING	17
7.1	HEAT LAMP	17
7.2	CONTROL PANEL	18
7.3	INTERNAL FUSE	18
7.4	BOTTOM ELEMENT	18
7.5	CIRCUIT DIAGRAM	19
7.6	WIRING DIAGRAM	20
8	FAULT FINDING	21
9	SPARE PARTS	22
10	SERVICE INFORMATION	22

1.0 APPLIANCE INFORMATION

Falcon Foodservice Equipment  P.I.N. STD. 

A Ser No. **B** MODEL **C** TYPE I.P.

ES, GB, GR, IE, IT, PT, SI	BE, FR	BG, CZ, DK, EE, FI, HR, LT, LV, NO, RO, SE, SI, SK, TR	CY, HU, IS, MT, NL	AT, CH	PL	LU	DE	-
I2H3+	I3+	I2H3B/P	I3B/P	I2H3B/P	I2E3B/P	I2E	I2E3B/P	-
20;28-30/37	28-30/37	20;30	30	20;50	20;30	20	20;30	-

D Cat. **E** p mbar

GAS TYPE	G20	G30	G31	
GAS RATE	m ³ /h	kg/h	kg/h	
Σ Qn	kW	kW	kW	kW

F GAS TYPE **G** GAS RATE **H** Σ Qn

I EL. Hz

J Σ kW kW **K**  kHz

L L1 A L2 A L3 A

A - Serial No

B - Model No

C - Flue Type

D - Gas Category

E - Gas Pressure

F - Gas Type

G - Gas Rate

H - Total Heat Input

I - Electrical Rating

J - Total Electrical Power

K - Magnetic Field Frequency

L - Electrical Phase Loading

2.0 OPERATION

2.1 COMPONENT PARTS / CONTROLS

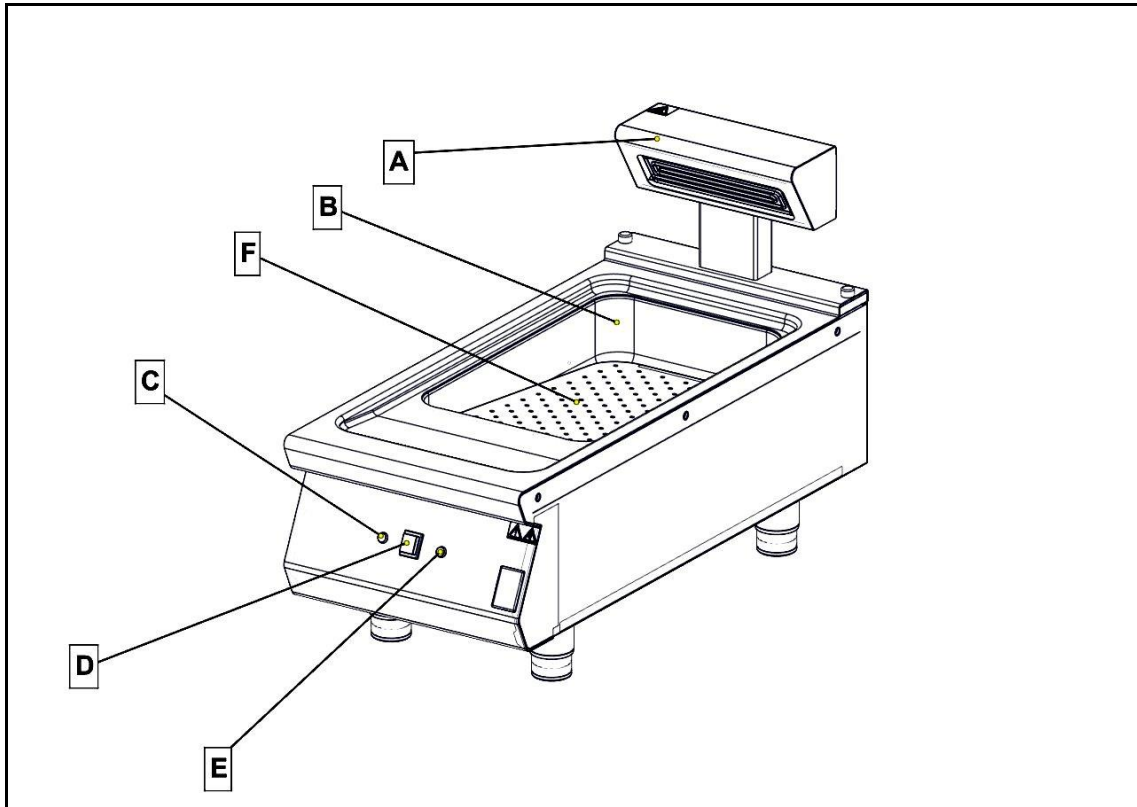

A – 500W Ceramic Heat Lamp

B – Pressed Bowl

C – Red Neon

D – ON/OFF Rocker Switch

E – Amber Neon

F – Perforated Plate

2.2 USING THE APPLIANCE

- 2.2.1 Before use, clean the appliance. See section 3.0.
- 2.2.2 Red neon indicates power to appliance.
- 2.2.3 Press switch to turn on heating elements as shown.
- 2.2.4 Amber neon indicates appliance is switched on and heating elements working.

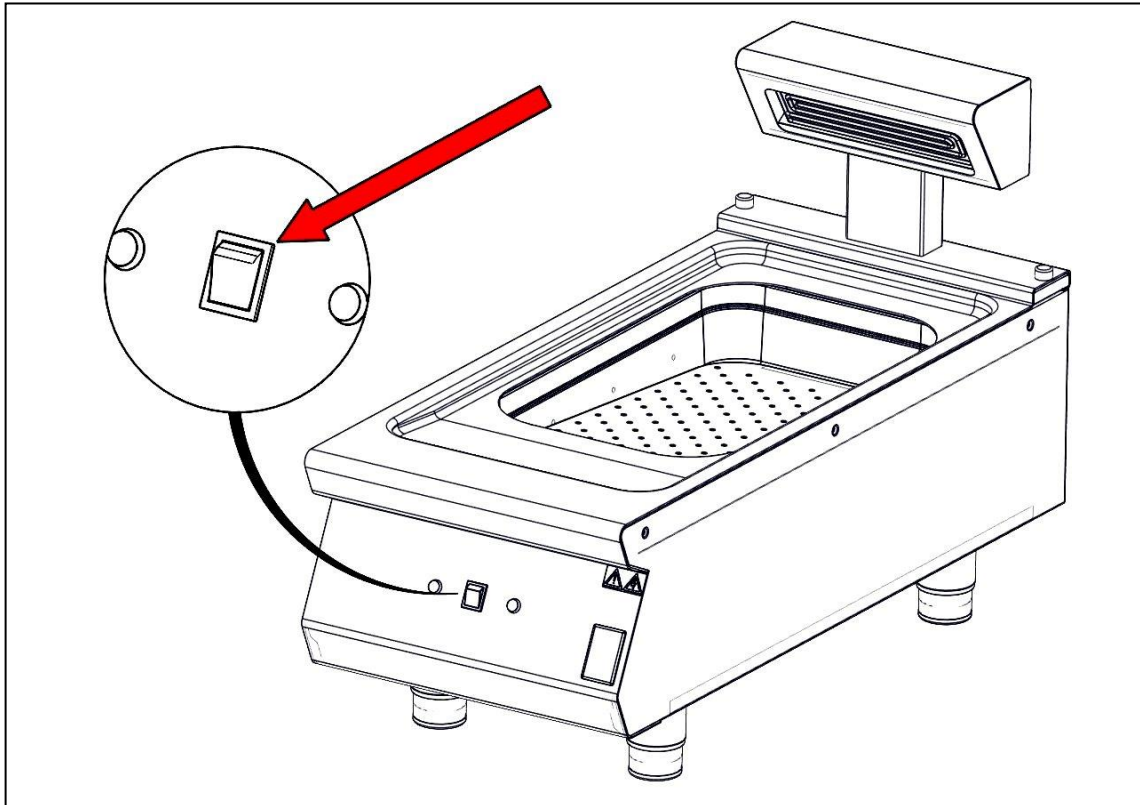

3.0 CLEANING, SERVICING AND MAINTENANCE

SERVICE INFORMATION

This unit carries an extensive mainland UK warranty. The warranty is in addition to and does not change your statutory or legal rights.

The warranty policy can be found on our website which details the conditions of the warranty and the exclusions.

<https://www.falconfoodservice.com/info-centre/policy>



Service calls to equipment under warranty will be carried out in accordance with the conditions of sale.

Warranty calls can be made between 8:30 am and 5:00 pm weekdays only.

To ensure your warranty enquiry is handled as efficiently as possible, ensure you have the following appliance information prior to calling us:

1. Model number – found on data plate
2. Serial number – found on data plate
3. Brief description of the issue

To contact Falcon for a warranty issue dial (UK only) 01786 455 200 and select Warranty Issues from the menu.



BEFORE ATTEMPTING ANY MAINTENANCE, ISOLATE THE APPLIANCE AT THE MAIN SWITCH AND TAKE STEPS TO ENSURE THAT IT IS NOT INADVERTAENTLY SWITCHED ON.



MAINTENANCE CHECK

Regular servicing of the appliance should be undertaken to ensure correct operation, it is functioning as intended, and safe to use. We recommend servicing after 2,500 hours of use, or annually, whichever comes first.

Any maintenance schedule should be carried out in accordance with SFG20 Maintenance Schedule. Should any issues with the integrity of the components be identified these should be replaced. If the appliance is not considered safe the unit should be removed from service and the responsible person advised why the unit is not safe to use and what remedial action is needed. Contents of the maintenance schedule should be agreed with the maintenance provider.

- 3.1 Turn off and cool down.
- 3.2 Clean bowl and perforated plate to ensure they are free from oil and grease.



FAILURE DUE TO LACK OF PROPER CLEANING IS NOT COVERED BY WARRANTY.

4.0 SPECIFICATION

- 4.1.1 This unit is suitable for AC supplies only.
- 4.1.2 The standard terminal arrangement is single phase (230V~).

Live	BROWN
Neutral	BLUE
Earth	YELLOW/GREEN



WARNING: THIS APPLIANCE MUST BE EARTHED

5.0 DIMENSIONS / CONNECTION LOCATIONS

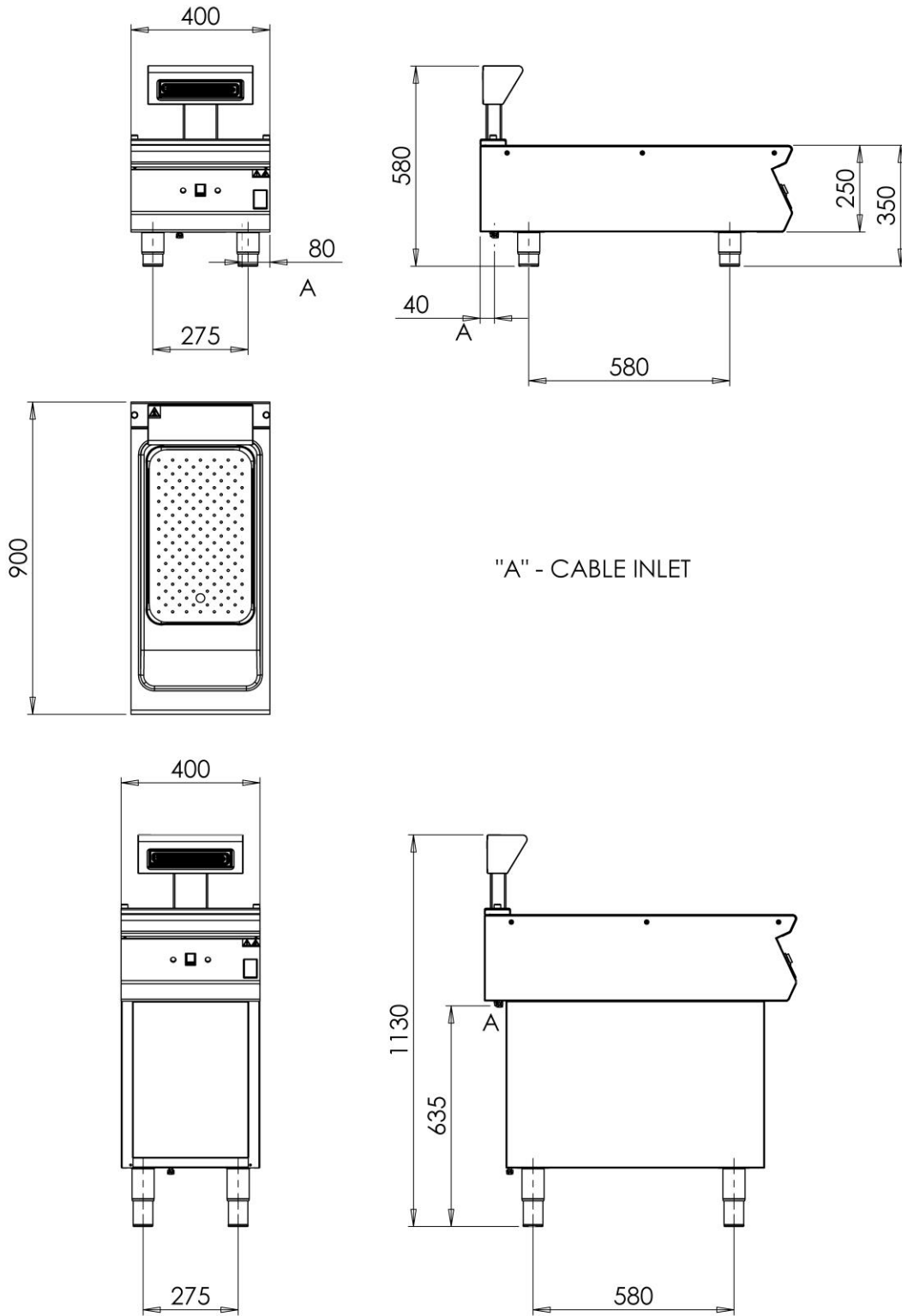

6.0 INSTALLATION

ELECTRICAL SAFETY AND ADVICE REGARDING SUPPLEMENTARY ELECTRICAL PROTECTION

Commercial kitchens and foodservice areas are environments where electrical appliances may be located close to liquids, or operate in and around damp conditions or where restricted movement for installation and service is evident.

The installation and periodic inspection of the appliance should only be undertaken by a qualified, skilled and competent electrician; and connected to the correct power supply suitable for the load as stipulated by the appliance data label.

The electrical installation and connections should meet the necessary requirements to the local electrical wiring regulations and any electrical safety guidelines.

We recommend:-

- Supplementary electrical protection with the use of a type A residual current device (RCD)
- Fixed wiring appliances incorporate a locally situated switch disconnector to connect to, which is easily accessible for switching off and safe isolation purposes. The switch disconnector must meet the specification requirements of IEC 60947.

Your attention is drawn to:-

BS 7671:2018–Guidance Note 8 - 8.13 : Other locations of increased risk

It is recognized that there may be locations of increased risk of electric shock other than those specifically addressed in Part 7 of BS 7671. Examples of such locations could include laundries where there are washing and drying machines in close proximity and water is present, and commercial kitchens with stainless steel units, where once again, water is present.

Where because of the perception of additional risks being likely, the installation designer decides that an installation or location warrants further protective measures, the options available include:

- Automatic Disconnection of Supply (ADS) by means of a residual current device having a residual operating current not exceeding 30mA;
- Supplementary protective equipotential bonding; and
- Reduction of maximum fault clearance time.

The provision of RCDs and supplementary bonding must be specified by the host organization's appointed installation designer or electrical contractor and installed by a suitably qualified and competent electrician so as to comply with Regulations 419.2 and 544.2

6.1 SITING / CLEARANCES

THIS APPLIANCE CAN BE SITED AGAINST A COMBUSTABLE WALL. CAUTION: IF SUITING THE NECESSARY CLEARANCES TO ANY CUMBUSTIBLE WALL MUST BE

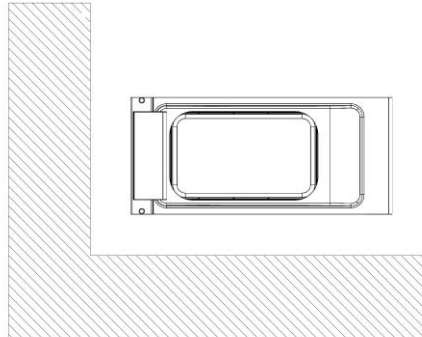

THE LARGEST FIGURE GIVEN FOR INDIVIDUAL APPLIANCES INSTRUCTIONS.

6.2 SUPPLY CONNECTION

6.2.1 A suitable supply cord is supplied that conforms to code designation 60245 IEC 57, cable type H07RN-F. This appliance is designed to, and must, be connected to fixed wiring. If cord is damaged, it must be replaced by a suitably qualified person. Access to mains terminal block is gained by removing control panel. (See 7.2)

6.2.2 This appliance is also provided with a terminal for connection of an external equipotential conductor. This terminal is an effective electrical contact with all fixed exposed metal parts of the appliance, and shall allow the connection of conductor having a nominal cross-section area of up to 10mm². It is located at the rear of the unit and identified by the following label and must only be used for bonding purposes.

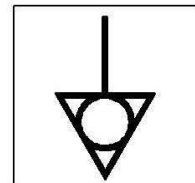

6.3 ELECTRICAL RATINGS

6.3.1 Electrical loading is as stated in table below and also on appliance data plate. The location of mains isolating switch should be identified for use in any event of an emergency or during cleaning.

Connection	Power Input Top Element	Power Input Bottom Element	A @ 230V	Internal Fuse Rating
L1	500W	460W	4A	8 A

6.4 ASSEMBLY

6.4.1 Position appliance and level using feet adjusters as shown below.

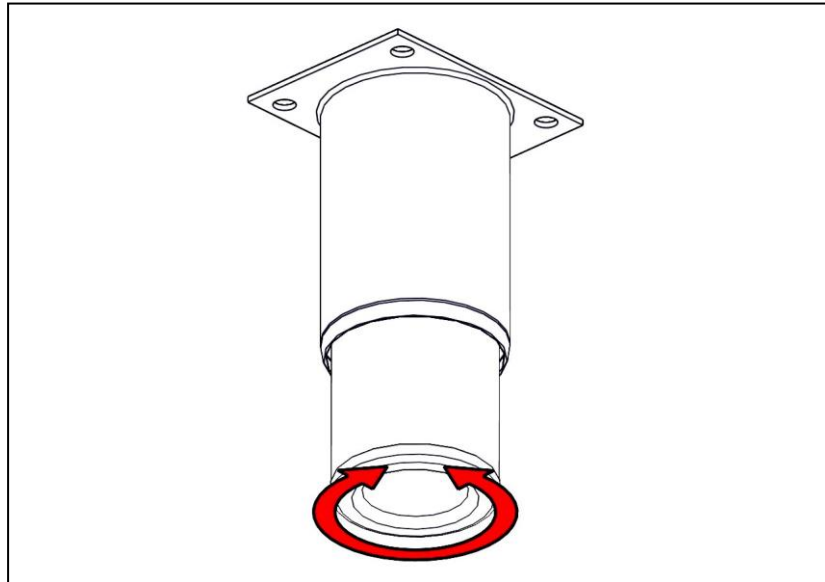

6.4.2 Connect appliance to electrical supply, as detailed in section 4.

6.5 COMMISSIONING

6.5.1 Switch on mains supply. Red neon will illuminate.

6.5.2 Press switch to turn on heating elements. Amber neon will illuminate.

6.5.3 Ensure both elements heat up.

If the appliance does not operate correctly please refer to section 7.0 and rectify the problem.



PLEASE FILL OUT THE INFORMATION TABLE ON THE FRONT COVER AFTER COMMISSIONING.

6.6 SUITING

“Patent No. GB 2540131”

- 6.6.1 Before levelling and suiting units ensure the units are fully built, including all accessories and castings.
- 6.6.2 Undo the 4 fixing screws on the control panel and remove.
- 6.6.3 Remove the hob rear infill and replace with rear suiting plate and fixings.
- 6.6.4 Remove the front side panel countersunk screw and suiting plate.

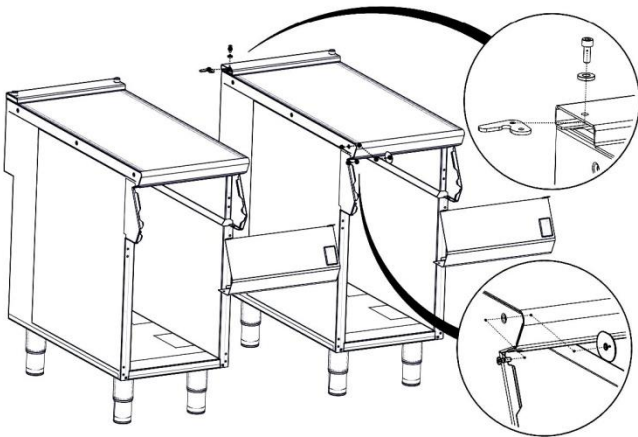

NOTE: The DLS system is designed to give a quick and easy suiting solution. If you require an improved seal between appliances we recommend you use, a food grade, high temperature silicon sealant. This can be supplied by Falcon part no – 523400021

- 6.6.5 Run a bead of silicon 5mm from profile edge as highlighted below.

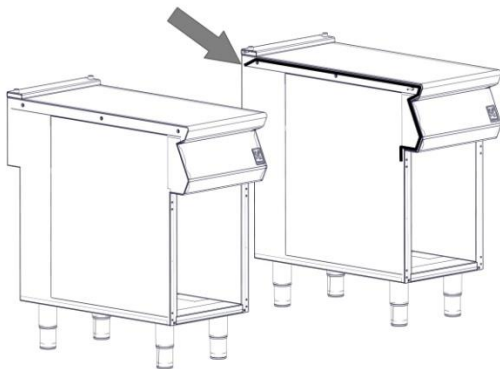

- 6.6.5 Slide suited units into position.

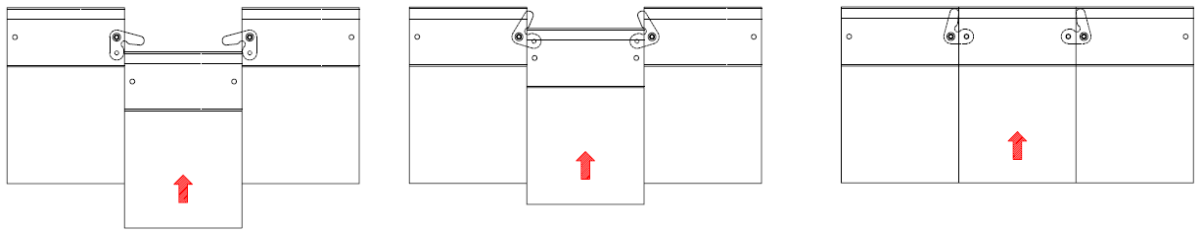

- 6.6.6 (A) Right hand unit: Screw the M5 x 40 screw (supplied in the kit) into one of the suiting plates as shown and then insert through the front fixing holes of both units.
- 6.6.7 (B) Left hand unit: Slide the penny and lock washer on to the screw and secure using the M5 nut.
- 6.6.8 (C) Remove the front bolts from feet, insert base tie plate and secure the bolts back into position.
- 6.6.9 (D) Replace fixings on the rear hob and tighten screw caps into position.

D

A

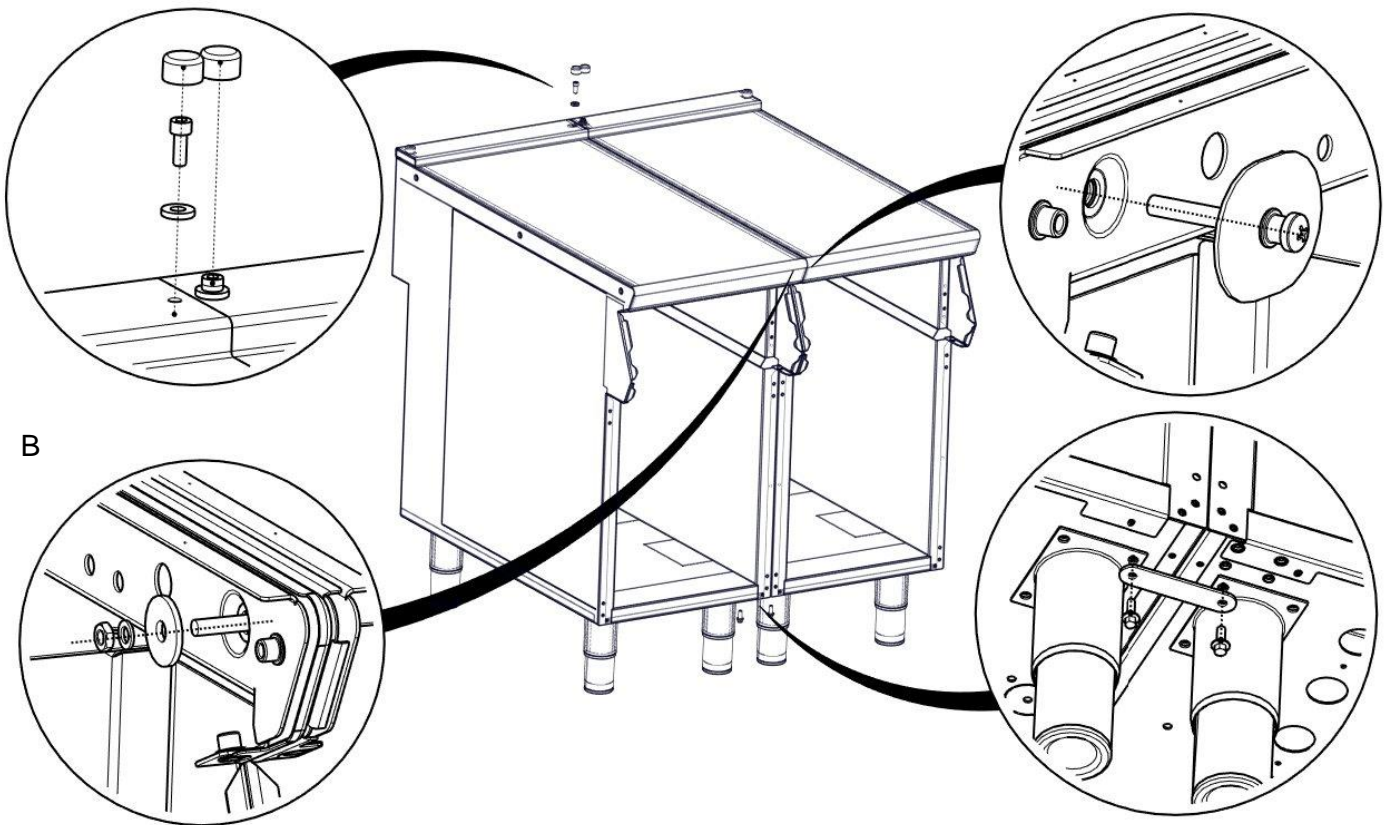

B

C

6.6.10 Replace control panel.

7.0 SERVICING

7.1 HEAT LAMP

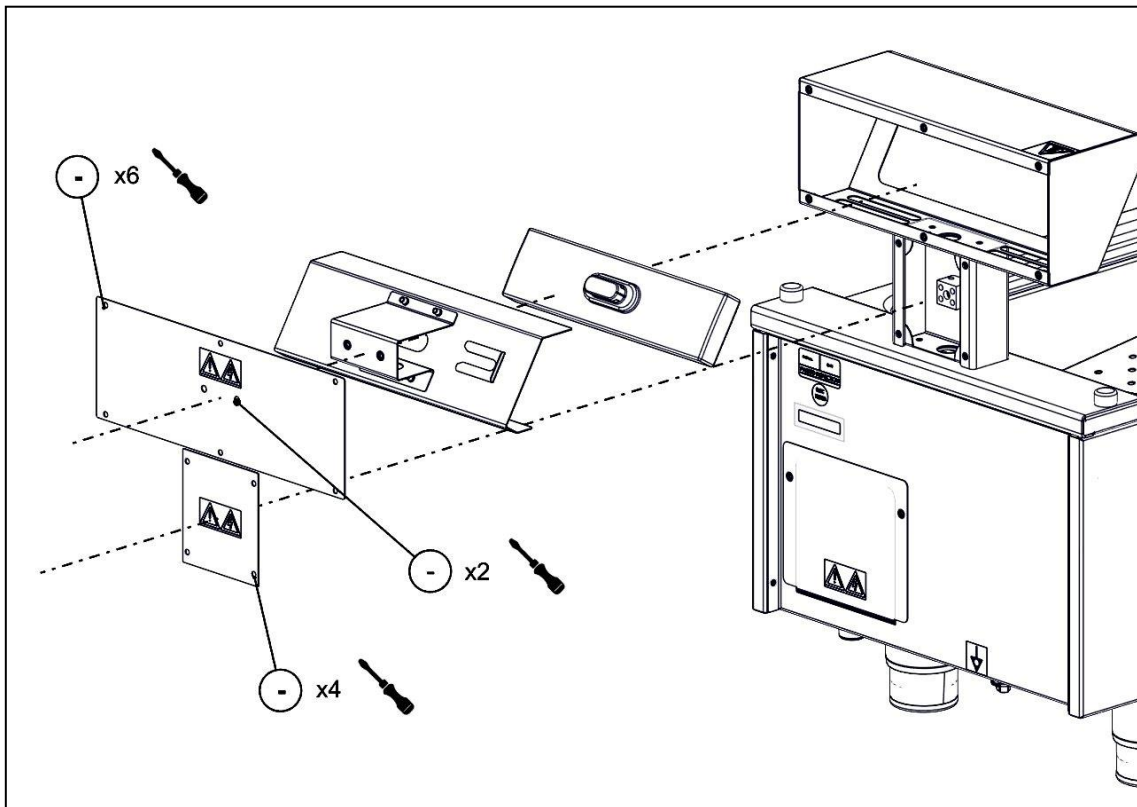

- 7.1.1 Disconnect appliance from mains supply.
- 7.1.2 Remove rear panels as shown.
- 7.1.3 Disconnect heat lamp connections from terminal block.
- 7.1.4 Remove heat lamp bracket as shown.
- 7.1.5 After replacement, check heat lamp's performance.

7.2 CONTROL PANEL

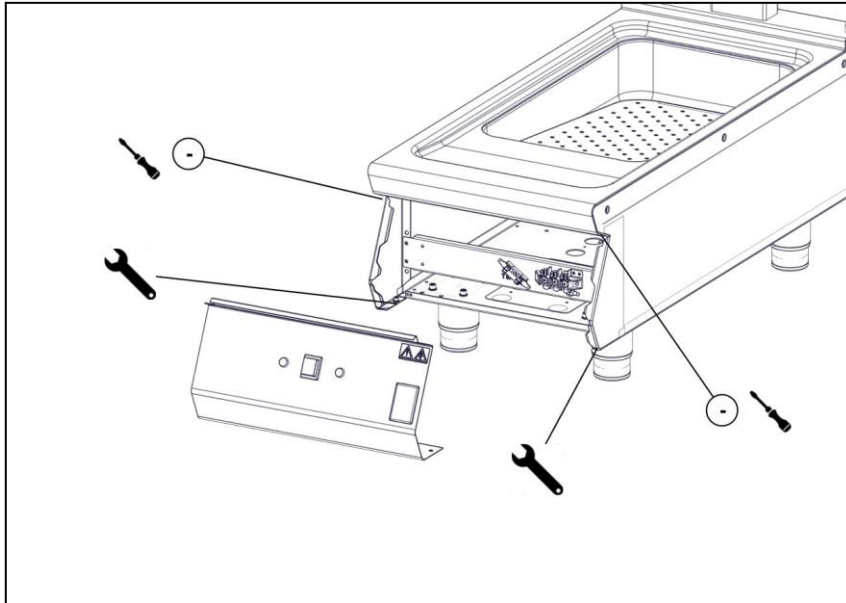

7.2.1 Remove control panel as shown.

7.3 INTERNAL FUSE

7.3.1 Remove control panel as shown in 7.2

7.3.2 Replace fuse.

7.4 BOTTOM ELEMENT

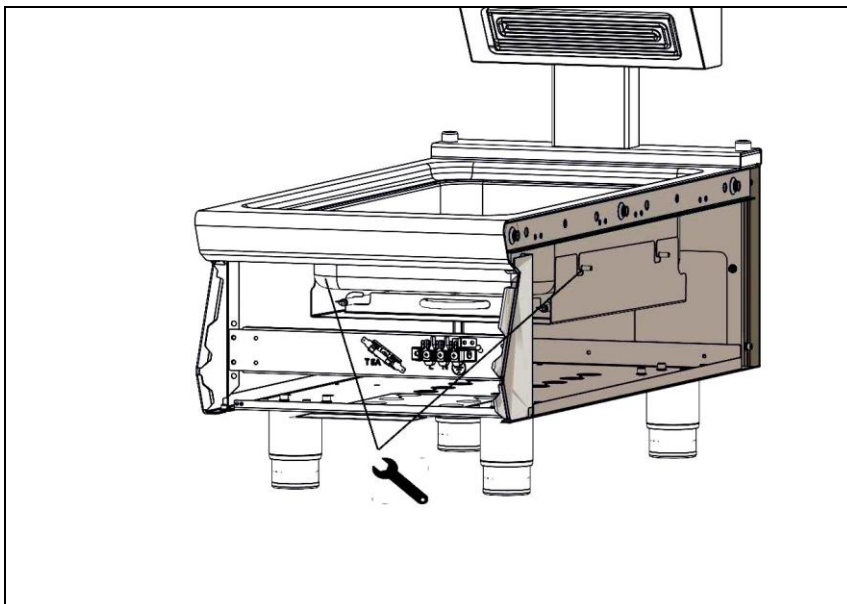

7.4.1 Remove control panel as shown in 7.2.

7.4.2 Loosen the 2 front M5 nuts as shown.

7.4.3 Lift element tray up, slide rearwards, lower tray clear of locating studs and remove.

7.4.4 Remove element clamps and earth cable.

7.4.5 Replace in reverse order

7.5 CIRCUIT DIAGRAM

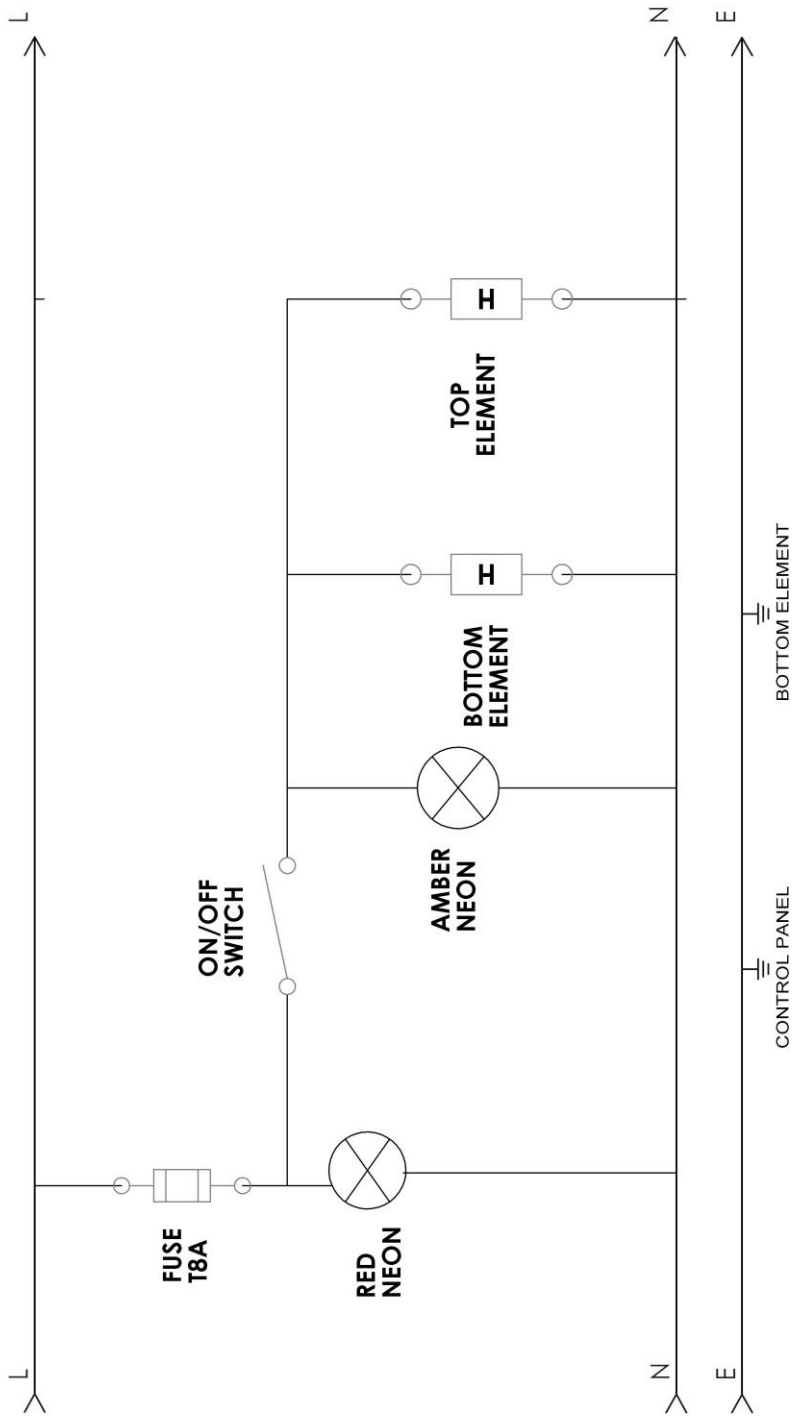

7.6 WIRING DIAGRAM

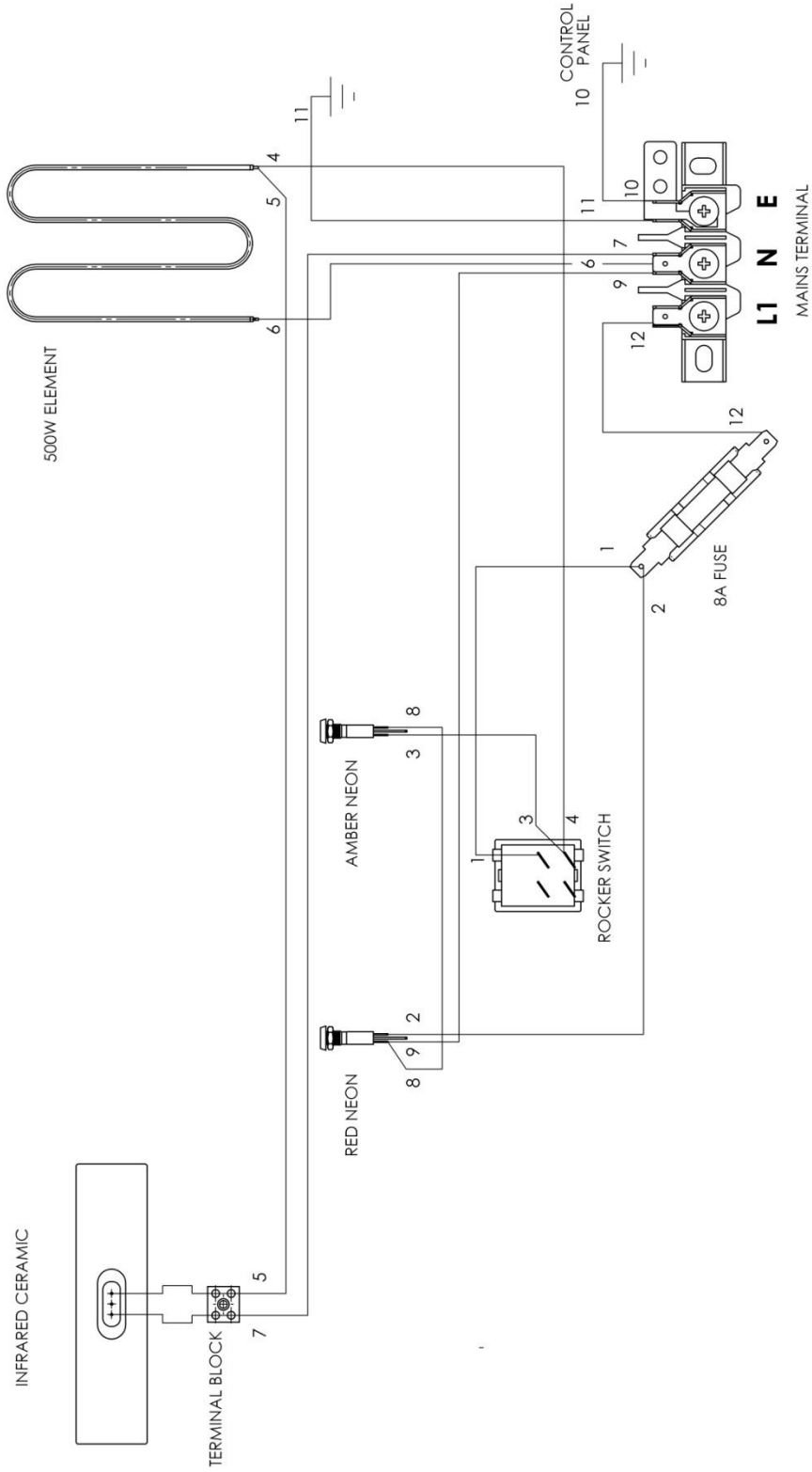

8 FAULT FINDING

FAULT	POSSIBLE CAUSES	REMEDY
No heat from ceramic heat lamp	Faulty element	Renew
	Faulty wiring	Diagnose, rectify/renew as necessary
No heat from bottom element	Faulty element	Renew
	Faulty wiring	Diagnose, rectify/renew as necessary
No power to unit (red neon does not illuminate)	Disconnected from mains power	Check, reconnect
	Blown Internal Fuse	Renew
No heat or amber neon when switched on (red neon illuminated)	Faulty rocker switch	Rectify/renew
	Fault in wiring	Rectify

9 SPARE PARTS

Main Spare Parts:

- Infrared Ceramic Heater 460W
- Terminal Block
- HS Base Element 460W
- Red Neon
- Amber Neon
- Rocker Switch
- 8A Fuse

When ordering spare parts please quote the following;

Model Number

Serial number

This information will be found on data plate attached to the appliance. (see 1.0)

Visit our website for further spares information.

10 SERVICE INFORMATION

It is recommended to have a maintenance contract with a local service provider.

To contact Falcon for a warranty issue dial (UK only) 01786 455 200 and select Warranty Issues from the menu.