



DOMINATOR*PLUS*

G3117D General Purpose Oven

Key features

- Full depth worktop surface
 - Provides valuable kitchen workspace
- Vitreous enamelled oven chamber
 - Easy to clean and to keep clean
- Wide oven temperature range of 120 - 270°C
 - Ideal to prepare a wide variety of food
- Piezo ignition to oven
 - Simple, trouble-free operation
- Drop down door to oven
 - Easy to load and unload
- Oven has 5 shelf positions and allows 2 shelf cooking
 - Versatile, ideal for a wide range of menu items
- Low profile door handle
 - Reduces intrusion into work space
- Laser-etched control icons
 - Permanent, indelible markings

Accessories

- Fully integrated extended flue
- Splashplate and plateshelf (not for use with extended flue)
- Oven shelf
- Factory fitted, adjustable castors
- Fixed installation kit



Similar Models

- G3117 GP Oven
- G3117DS GP oven on stand with drop down door
- G3117/2 Two tier GP oven
- E3117D Electric GP oven with drop down door
- E3117S Electric GP oven on stand
- E3117/2 Two tier electric GP oven

General Purpose Oven

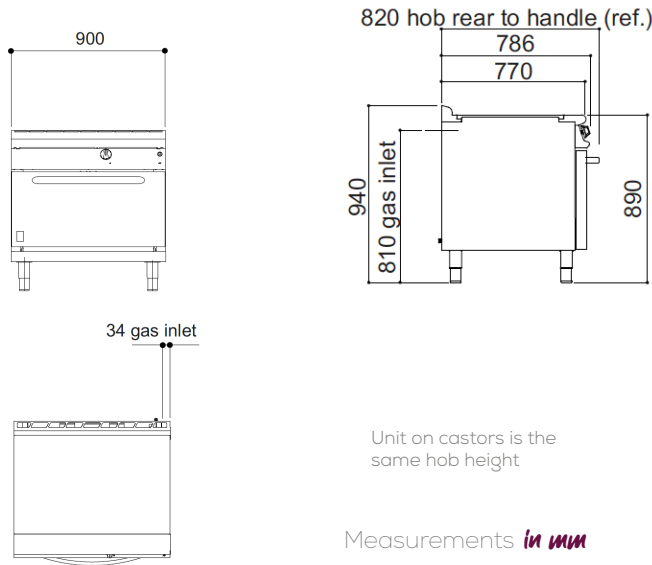

Installation notes

Adequate ventilation must be provided to supply sufficient fresh air for combustion and to allow easy removal of any such products that may present a risk to health. Please consult current legislation for details that relate to specific locations.

Install unit on a level, fireproof surface in a well-lit, draught free position. If floor is made of a combustible material, local fire requirements must be checked to ensure compliance.

A clearance of 150mm should be observed between appliance and any combustible wall.

Specification details

Total rating (natural and propane - kW - Nett)	7.1		
Total rating (natural and propane - btu/hr - gross)	26,600		
Inlet size (natural and propane)	3/4" BSP		
Flow rate - natural (m ³ /hr)	0.80		
Flow rate - propane (kg/hr)	0.60		
Inlet pressure (natural and propane - mbar)	20 / 37		
Operating pressure (natural and propane - mbar)	15 / 37		
Oven burner rating * (natural and propane - kW)	7.1		
Oven burner rating * (natural and propane - btu/hr)	26,600		
Oven dimensions (w x d x h - mm)	700 x 535 x 430		
Oven shelf (w x d - mm)	700 x 535		
Gastronorm compatibility	2/1		
Weight (kg)	120		
Packed weight (kg)	133		
Packed dimensions (w x d x h - mm)	1000 x 1000 x 1100		
GTIN numbers			
Nat Gas (feet)	Nat Gas (castors)	LPG (feet)	LPG (castors)

