

ORAC1

HIGH SPEED OVEN

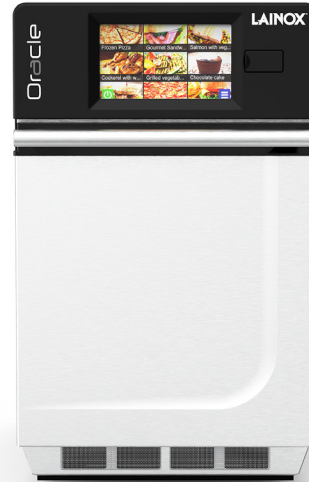

When everything needs to be fast, you need an oven that does more to help cook delicious food. Everything is faster with ORACLE, from installation to serving customers. All you have to do is touch the icon of the dish you want and start the cooking process, thanks to the touch screen interface and the numerous pre-configured recipes.



IMPINGEMENT

Power up to 3 kW guarantees excellent toasting and browning.



CONFIGURABLE DISPLAY

In addition to its highly intuitive 7" touch screen display, ORACLE has a customisable image-based menu which eliminates language and vocabulary barriers.



CONVECTION

Temperature from 95°C to 270°C with adjustable fan speed.



CONNECTED

Standard WiFi, Ethernet and USB connections.



MICROWAVE

Power up to 1 kW for rapid heating and reduced cooking times.



INSTANTLY CLEAN

Thanks to the standard supply non-stick lining in the oven and rapid cooling system, ORACLE is quickly cleaned at the end of the day.

TECHNICAL DATA

Capacity	lt	17,2	Consumption	A	16
Cooking chamber dimensions	mm	312 x 312 x 178 h	Impingement	kW	3
External dimensions	mm	358 x 743 x 578 h	Microwave	kW	1
Dimensions with packing	mm	600 x 900 x 800 h	Power supply voltage	V	1N-AC 230 V
Weight - Net / Gross	kg	53 / 68	Frequency	Hz	50
Working temperature	°C	95°C / 270°C	Plug configuration		CEE 7 / 7 "Schuko"
Total electric power	kW	3,68	Cable length	mt	1,5

Optional electric configuration, without extra charge - To be requested when ordering oven

Models	Total electric power	Power Output		Power supply voltage	Plug configuration	Cable length	Option code	
		Impingement	Microwave					
ORAC1	3,6 kW - 18,2 A	3 kW	1 kW	1N-AC 208 V - 60 Hz 1N-AC 240 V - 60 Hz	NEMA 6-20		1,5 mt.	OR620
	2,45 kW - 13 A	3 kW	1 kW	1N-AC 230 V - 50 Hz 1N-AC 240 V - 50 Hz	BS1363/A		1,5 mt.	OR1363
	3,25 kW - 15 A	3 kW	1 kW	1N-AC 230 V - 50 Hz 1N-AC 240 V - 50 Hz	A53112		1,5 mt.	OR53112

ORAC1

COOKING METHODS

- IMPINGEMENT - 3 KW
- CONVECTION - 95°C / 270° C
- MICROWAVE - 1 KW
- MICROWAVE DEFROST FUNCTION.
- MANUAL UP TO 4 CYCLES.
- PROGRAMMABLE WITH THE ABILITY TO STORE 1200 COOKING PROGRAMMES IN AUTOMATIC SEQUENCE (UP TO 4 CYCLES), ASSIGNING A NAME AND DEDICATED ICON.

OPERATION

- 7" FULLY CUSTOMISABLE TOUCH SCREEN DISPLAY.
- AUTOMATIC PRE-HEATING.

CLEANING AND MAINTENANCE

- APPROVED DETERGENTS CAN BE USED DIRECTLY ON THE SMOOTH DOOR SURFACE.
- REMOVABLE, NON-STICK COOKING CHAMBER LINING FOR EASY CLEANING.
- MAGNETIC AIR FILTERS CAN BE CLEANED IN ONE GO.
- RAPID COOLING FOR FAST CLEANING AT END OF DAY.

CONTROL MECHANISMS

- SILENT FUNCTION - THE FAN SPEED AUTOMATICALLY ADJUSTS BASED ON THE OPERATING MODE.
- REMINDER TO CLEAN AIR FILTERS.
- STANDARD SUPPLY WI-FI/ETHERNET CONNECTION TO UPDATE SOFTWARE AND UPLOAD/DOWNLOAD COOKING PROGRAMMES.
- STANDARD SUPPLY USB CONNECTION TO UPDATE SOFTWARE AND UPLOAD/DOWNLOAD COOKING PROGRAMMES.

CONSTRUCTION

- EXTERNAL STAINLESS STEEL FINISH.
- FRONT CONTROL PANEL IN PAINTED FINISH.
- STAINLESS STEEL OVEN CHAMBER WITH BEVELLED EDGES.
- BUILT-IN CATALYTIC CONVERTER FOR HOOD-FREE USE.
- PULL-DOWN DOOR WITH ERGONOMIC HANDLE.
- WHEN OPEN, THE DOOR SLIDES UNDER THE COOKING SURFACE OF THE OVEN, ALLOWING THE FOOD TO REMOVED SAFELY WITHOUT THE RISK OF BURNS.
- IPX3 PROTECTION AGAINST WATER SPLASHES.

STANDARD EQUIPMENT

- COOKING PLATE - SMOOTH
- NON-STICK LINING KIT
- WI-FI CONNECTION
- USB CONNECTION
- POWER CABLE AND PLUG

OPTIONAL - TO BE REQUESTED WHEN ORDERING OVEN

- **OR620** - OPTIONAL ELECTRIC CONFIGURATION
- **OR1363** - OPTIONAL ELECTRIC CONFIGURATION
- **OR53112** - OPTIONAL ELECTRIC CONFIGURATION

EXTRA ACCESSORIES THAT CAN BE INSTALLED FOLLOWING PURCHASE

- **OCTL140** - TEFLON TRAY - SMOOTH - 2 PCS. (140 X 280 X 25 H)
- **OCTL280** - TEFLON TRAY - SMOOTH - 2 PCS. (280 X 280 X 25 H)
- **OCTF150** - TEFLON TRAY - PERFORATED - 2 PCS. (150 X 300 X 25 H)
- **OCTF300** - TEFLON TRAY - PERFORATED - 2 PCS. (300 X 300 X 25 H)
- **OPRG** - GRILL PLATE - RIFLED. NON-STICK HEAT INPUT PLATE - ALUMINIUM ALLOY (305 X 295 X 5 H)
- **OPPC** - STONE PLATE (280 X 280 X 15 H)
- **OPGL** - SPEEDY PANINI - DOUBLE-SIDED GRIDDLE PLATE FOR SANDWICHES
- **OPFA** - ALUMINIUM PEEL (190 X 330)
- **OPC10** - SUPPORT SURFACE FOR COOKING ACCESSORIES
- **OKRA** - NON-STICK LINING KIT - PACK OF 4 PCS.
- **OSOCL** - LIQUID OVEN DETERGENT - CAPACITY 1 L. - PACK OF 6 PCS.
- **OSOPR** - LIQUID OVEN PROTECTOR - CAPACITY 1 L. - PACK OF 6 PCS.
- **OPSA** - UPPER SHELF REST
- **OPCP** - REAR COVER PANEL
- **OSR20** - STAINLESS STEEL FLOOR STAND WITH ADJUSTABLE FEET/WHEELS WITH LOW SHELF - TO BE ASSEMBLED (700 X 800 X 850 H)
- **ORP04** - CASTER KIT FOR FLOOR STANDS, 2 WITH BRAKE

ORAC1

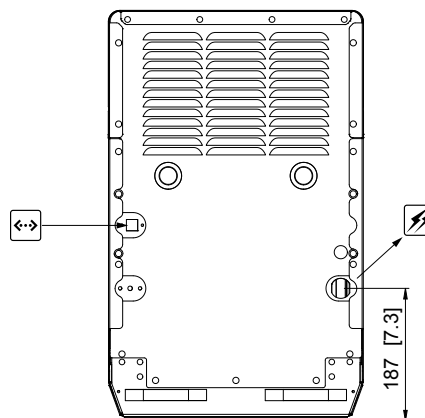
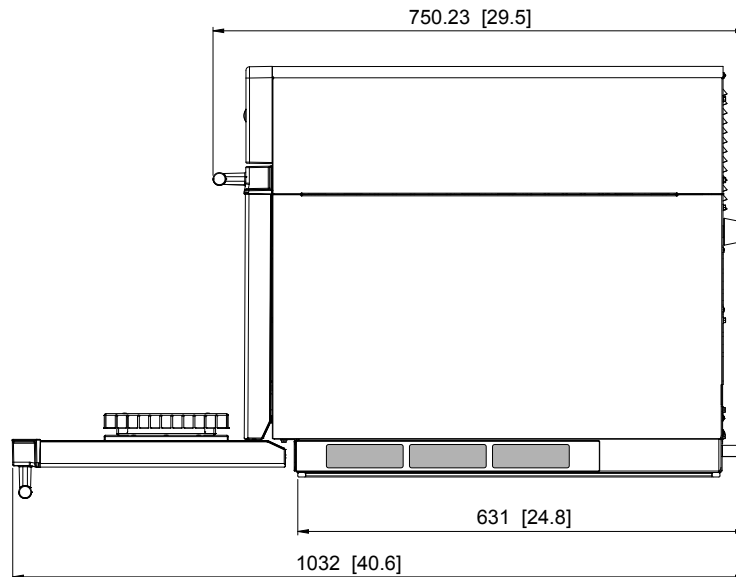
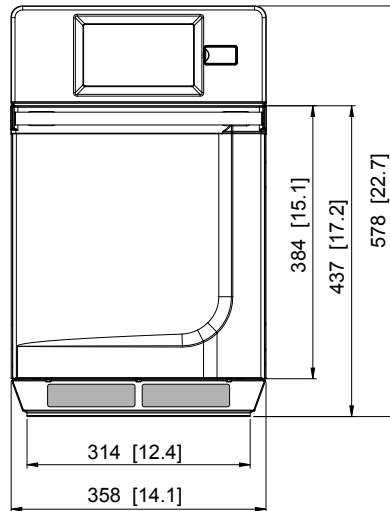
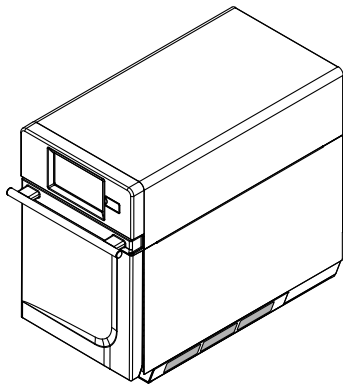

Dimensions: Millimeters [inches]

I dati riportati sul presente documento sono da ritenersi non vincolanti. L'azienda si riserva di apportare modifiche in qualsiasi momento senza preavviso. The data reported in this document is to be considered non-binding. The company reserves the right to make changes at any time, without prior notice. Les données indiquées dans ce document doivent être considérées non contraignantes. La société se réserve le droit d'apporter des modifications à n'importe quel moment et sans préavis. Die hier aufgeführten Daten sind nicht als bindend zu betrachten. Die Firma behält sich das Recht vor, in jedem beliebigen Moment ohne Vorankündigung Änderungen anzubringen. Los datos mostrados en este documento se deben considerar no vinculantes. La empresa se reserva el derecho de realizar cambios en cualquier momento sin previo aviso. Данные, приведенные в настоящем документе, не являются неаменными. Компания оставляет за собой право вносить изменения в любой момент без предварительного оповещения.

CE IPX3



10.02.2020

LAINOX

LAINOX ALI Group Srl
Via Schiaparelli 15
Z.I. S. Giacomo di Veglia
31029 Vittorio Veneto (TV) · Italy

Tel +39 0438 9110
Fax +39 0438 912300
lainox@lainox.it
www.lainox.com

