



SERVICING / INSTALL INSTRUCTIONS

COOK AND HOLD SINGLE / DOUBLE OVEN

CH15-11 / CH30-11
CH15-11P / CH30-11P

Read these instructions before use

DATE PURCHASED:

MODEL NUMBER:

SERIAL NUMBER:

DEALER:

SERVICE PROVIDER:

T101124

Rev No: REV 1
Published: 25/5/2026

Dear Customer

Thank you for choosing Falcon Foodservice Equipment.

This manual can be downloaded from www.falconfoodservice.com or scan here:



IMPORTANT: Please keep this manual for future reference.

Falcon Foodservice Equipment

HEAD OFFICE

Wallace View, Hillfoots Road,

Stirling, FK9 5PY, Scotland

Tel: 01786 455200

PREVENTATIVE MAINTENANCE CONTRACT

To obtain maximum performance from this unit regular servicing of the appliance should be undertaken to ensure correct operation, it is functioning as intended, and safe to use. We recommend servicing in accordance with SFG20 Maintenance Schedules and as a minimum, after 2,500 hours of use, or annually, whichever comes first and that a maintenance contract be arranged with an appointed service contact. Visits may then be made at agreed intervals to carry out adjustments and repairs.



WEEE Directive Registration No. WEEE/DC0059TT/PRO

At end of appliance life, dispose of appliance and any replacement parts in a safe manner, via a licensed waste handler. Appliances are designed to be dismantled easily and recycling of all material is encouraged whenever practicable.

CONTENTS

1.0	SYMBOLS	6
2.0	SAFETY GUIDANCE	7
2.1	GENERAL SAFETY	7
2.2	ELECTRIC SAFETY:.....	8
2.3	IMPORTANT INFORMATION	9
3.0	APPLIANCE INFORMATION	10
4.0	APPLIANCE OVERVIEW AND CONTROLS	11
4.1	COMPONENT PARTS CH15-11/ CH15-11P.....	11
4.2	COMPONENT PARTS CH30-11 / CH30-11P.....	12
4.3	CONTROLS CH15-11 / CH15-11P	13
4.4	CONTROLS CH30-11 / CH30-11P	13
4.5	OVEN CONTROL LAYOUT.....	14
5.0	OPERATION	14
5.1	TURNING ON THE APPLIANCE.....	14
5.2	STARTING A COOK CYCLE:.....	14
5.3	STOPPING A COOKING CYCLE	15
5.4	RETURNING TO THE PREVIOUS OR HOME SCREEN	16
5.5	RETURNING TO THE STANDBY SCREEN.....	16
5.6	TURNING OFF THE UNIT.....	17
5.7	CHANGING THE DATE OR TIME.....	17
5.8	MONITORING THE ENERGY CONSUMPTION AND HEATING ELEMENT USAGE.....	18
5.9	USB PORT	19
5.10	DOWNLOADING HACCP DATA VIA USB.....	19
5.11	HOW TO DOWNLOAD /UPLOAD CONFIGURATION PARAMETERS VIA USB	20
5.12	HOW TO ACCESS/CHANGE THE CONFIGURATION PARAMETERS:	22
5.13	LIST OF PASSWORDS	26
6.0	MAINTENANCE AND SAFETY CHECKS	27
6.1	MAINTENANCE CHECKS.....	27
6.2	MAINTENANCE	28
7.0	SPECIFICATION	29
7.1	APPLIANCE WEIGHT TABLE	29
7.2	TECHNICAL DATA TABLE(S):.....	29
8.0	DIMENSIONS	30
8.1	CH15-11 / CH15-11P SINGLE OVEN	30

8.2	CH30-11 / CH30-11P DOUBLE OVEN.....	31
9.0	INSTALL, POSITIONING, CLEARANCES, POWER & CALIBRATION	32
9.1	POSITIONING.....	32
9.2	POSITIONING CLEARANCES.....	33
9.3	ELECTRIC SUPPLY & CONNECTION.....	35
9.4	OVEN CALIBRATION:	37
9.5	CALIBRATE OF THE CORE PROBES (IF THE UNIT IS EQUIPPED WITH PROBES.).....	38
10.0	SERVICING	39
10.1	THERMOCOUPLE REPLACEMENT	39
10.2	OVEN SAFETY THERMOSTAT RESET.....	40
10.3	OVEN SAFETY THERMOSTAT REPLACEMENT	41
10.4	DRIP TROUGH GASKET REPLACEMENT	43
10.5	COVER REMOVAL / REPLACEMENT	44
10.6	TOUCHSCREEN REPLACEMENT.....	45
10.7	I/O POWERBOARD REPLACEMENT	46
10.8	SIDE PANEL REMOVAL	47
10.9	SIDE ELEMENT REMOVAL / REPLACEMENT	48
10.10	BASE ELEMENT REMOVAL / REPLACEMENT	51
10.11	FUSE REPLACEMENT.....	53
10.12	RELAY REMOVAL / REPLACEMENT	54
10.13	SOLID STATE RELAY REPLACEMENT	55
10.14	COOLING FAN REPLACEMENT.....	56
10.15	TRANSFORMER REPLACEMENT.....	57
10.16	CORE TEMP PROBE PLUG REPLACEMENT	58
10.17	DOOR SEAL REPLACEMENT.....	59
10.18	DOOR PROXIMITY SWITCH REPLACEMENT	60
10.19	DOOR REMOVAL / REPLACEMENT	61
10.20	MCB ACCESS PANEL REMOVAL	62
10.21	HOW TO VIEW AND UPDATE FIRMWARE:	63
	VIEW SOFTWARE REVISION:.....	63
	UPDATE THE FIRMWARE (IF REQUIRED):.....	63
10.22	CONTROL BOARD (I/O BOARD)	64
10.23	TOUCH SCREEN (USER INTERFACE) AND EVLINK (WI-FI)	65
11.0	ALARMS.....	65
11.1	OVEN DOOR ALARM.....	66
11.2	POWER FAILURE ALARM	66

11.3	THERMAL SWITCH ALARM	67
11.4	CHAMBER HIGH TEMPERATURE ALARM	67
11.5	HIGH BOARD TEMPERATURE ALARM	67
11.6	MAIN CARD (CONTROL BOARD) COMMUNICATION ALARM	68
11.7	NEEDLE PROBE ALARM	68
11.8	CHAMBER PROBE ALARM	69
11.9	POWER CARD/CONTROL MODULE COMPATIBILITY	69
11.10	POWER CONSUMPTION ALARM	69
11.11	HEATING ISSUE ALARM	70
12.0	FAULT DIAGNOSTIC & RECTIFICATION	71
12.2	OVEN DOOR ALARM.....	72
12.3	CHAMBER HIGH TEMPERATURE ALARM	73
12.4	HIGH BOARD TEMPERATURE ALARM	74
	74
12.5	MAIN CARD (CONTROL BOARD) COMMUNICATION ALARM.....	75
	75
12.6	CORE (NEEDLE) PROBE ALARM	76
12.7	CHAMBER PROBE (OPERATING THERMOSTAT) ALARM	77
12.8	HEATING ISSUE ALARM / NO HEATING OR SLOW HEATING	78
12.9	TOUCH SCREEN NOT TURNING ON	79
	79
13.0	SPARE PARTS.....	80
14.0	SERVICE INFORMATION.....	80

1.0 SYMBOLS



SCREWDRIVER



SPANNER

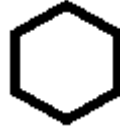

SOCKET



READ MANUAL



WARNING



**WARNING
ELECTRICAL**



FIRE RISK



BURN RISK

2.0 SAFETY GUIDANCE

Read all these instructions carefully before attempting to install, commission or service this appliance.

2.1 GENERAL SAFETY



- 2.1.1** These instructions are only valid if the country code appears on the appliance. If the code does not appear on the appliance, refer to the technical instructions for adapting the appliance to the conditions for use in that country.
- 2.1.2** These appliances have been UKCA/CE-marked based on compliance with the Electrical Equipment (safety) Regulations/LVD Directives and Electromagnetic Compatibility (EMC) Regulations/Directives for the Countries.
- 2.1.3** Check that no damage has occurred to the appliance or supply cord during transit. If damage has occurred, do not use this appliance.
- 2.1.4** Ensure that the appliance is unplugged, and the cable is stored safely before moving the appliance.
- 2.1.5** Do not move the appliance on a slope and/or uneven surface.
- 2.1.6** Do not block the appliance ventilation holes, located at the back of the control panel, as this may cause the appliance's control system to overheat.
- 2.1.7** Ensure the supply cord is routed free from the appliance to avoid damage and it away from all sources of heat and water.
- 2.1.8** Installation must comply with all applicable national or local regulations. Attention must be paid to: safety (installation & use) regulations, health and safety at work act, local and national building regulations, fire precautions act.
- 2.1.9** The installer must instruct the responsible person(s) of the correct operation and maintenance of the appliance.
- 2.1.10** The oven must be allowed to cool to a safe temperature before attempting any service or maintenance on the unit.
- 2.1.11** Put a documented system in place for periodic inspections, testing and maintenance of our electrical appliances. Check that the fixed electrical installation has been inspected and tested by a competent electrical contractor (e.g. NICEIC-approved or ECA member) as prescribed in BS7671, within the last 5 years.
- 2.1.12** Unless otherwise stated, parts and setting which have been protected by the manufacturer must not be adjusted by the installer.
- 2.1.13** During Servicing of the appliance, where applicable, please ensure seals are checked. If the integrity of the seal is compromised, it must be replaced.
- 2.1.14** Suitable protective clothing must be worn when cleaning this appliance.
- 2.1.15** The appliance must not be cleaned with a jet of water or be steam cleaned. Do not use acid or halogen-based (e.g. chlorine) descaling liquids, flammable liquids, cleaning aids or cleaning powders.
- 2.1.16** Failure due to lack of proper cleaning is not covered by warranty.
- 2.1.17** After positioning, lock the casters securely to prevent unintended or hazardous movement.

- 2.1.18** Training and Competence: To help ensure the safe use of this appliance there is a requirement for you to provide whatever information, instruction, training and supervision as is necessary to ensure, so far as is reasonably practicable, the health and safety of all users.
- 2.1.19** For further help and information on training and competence we refer you to the Health & Safety Executive website; www.hse.gov.uk document ref: health and safety training INDG345. International customers should default to the health and safety guidelines provided by your government body.
- 2.1.20** Before installing or servicing this appliance, read and understand the User Manual. Ensure all users are properly informed and trained in safe operation. Failure to follow the instructions in both manuals may result in injury or equipment damage.



2.2 ELECTRIC SAFETY:

- 2.2.1** To prevent electric shocks, this appliance must be earthed – only connect it to a properly earthed socket outlet.
- 2.2.2** This unit is fitted with an equipotential connection at the rear on the base.
- 2.2.3** We recommend, Supplementary electrical protection with the use of a type A residual current device (RCD).
- 2.2.4** Fixed wiring appliances incorporate a locally situated switch disconnecter to connect to, which is easily accessible for switching off and safe isolation purposes. The switch disconnecter must meet the specification requirements of IEC 60947.
- 2.2.5** Before attempting any maintenance, isolate the appliance at the mains switch and take steps to ensure that it is not inadvertently switched on.
- 2.2.6** Ensure any separate electric switches provided for cooking equipment and/or extractor fans are accessible and clearly labelled.

2.3 IMPORTANT INFORMATION

ELECTRICAL SAFETY AND ADVICE REGARDING SUPPLEMENTARY ELECTRICAL PROTECTION

Commercial kitchens and food service areas are environments where electrical appliances may be located close to liquids, or operate in and around damp conditions or where restricted movement for installation and service is evident.

The installation and periodic inspection of the appliance should only be undertaken by a qualified, skilled and competent electrician; and connected to the correct power supply suitable for the load as stipulated by the appliance data label.

The electrical installation and connections should meet the necessary requirements to the local electrical wiring regulations and any electrical safety guidelines.

We recommend:-

- Supplementary electrical protection with the use of a type A residual current device (RCD)
- Fixed wiring appliances incorporate a locally situated switch disconnector to connect to, which is easily accessible for switching off and safe isolation purposes. The switch disconnector must meet the specification requirements of IEC 60947.

Your attention is drawn to:-

BS 7671:2018–Guidance Note 8 - 8.13 : Other locations of increased risk

It is recognized that there may be locations of increased risk of electric shock other than those specifically addressed in Part 7 of BS 7671. Examples of such locations could include laundries where there are washing and drying machines in close proximity and water is present, and commercial kitchens with stainless steel units, where once again, water is present.

Where because of the perception of additional risks being likely, the installation designer decides that an installation or location warrants further protective measures, the options available include:

- Automatic Disconnection of Supply (ADS) by means of a residual current device having a residual operating current not exceeding 30mA;
- Supplementary protective equipotential bonding; and
- Reduction of maximum fault clearance time.

The provision of RCDs and supplementary bonding must be specified by the host organization's appointed installation designer or electrical contractor and installed by a suitably qualified and competent electrician so as to comply with Regulations 419.2 and 544.2

3.0 APPLIANCE INFORMATION

These appliances have been UKCA/CE-marked based on compliance with the Electrical Equipment (safety) Regulations/LVD Directives and Electromagnetic Compatibility (EMC) Regulations/Directives for the Countries as stated on the data plate.

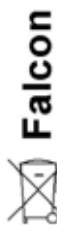
 Foodservice Equipment	STD	MODEL	SERIAL NO.	GAS TYPE	
	SUPPLY PRESS	COUNTRY	PIN/CE	CAT	
	CE	UKCA	IP RATING		
	INJECTOR MARKING	HEAT INPUT	GAS RATE	ADJ PRESS	
				SET PRESS OVEN	
				SET PRESS BOILER	
	RATED ELECTRIC INPUT		VOLTS	OUTPUT FREQ	EXT FUSE
	PHASE LOADING	L1	L2	L3	INT FUSE

- A** - Serial No
 - B** - Model No
 - C** - Marked
 - D** - Total Electrical Power
 - E** - Electrical Voltage Rating
 - F** - Electrical Phase Loading
 - G** - Supply Frequency
 - H** - Internal Fuse Rating
- Note:** Use only **0.5A T-type fuse**

4.0 APPLIANCE OVERVIEW AND CONTROLS

4.1 COMPONENT PARTS CH15-11/ CH15-11P

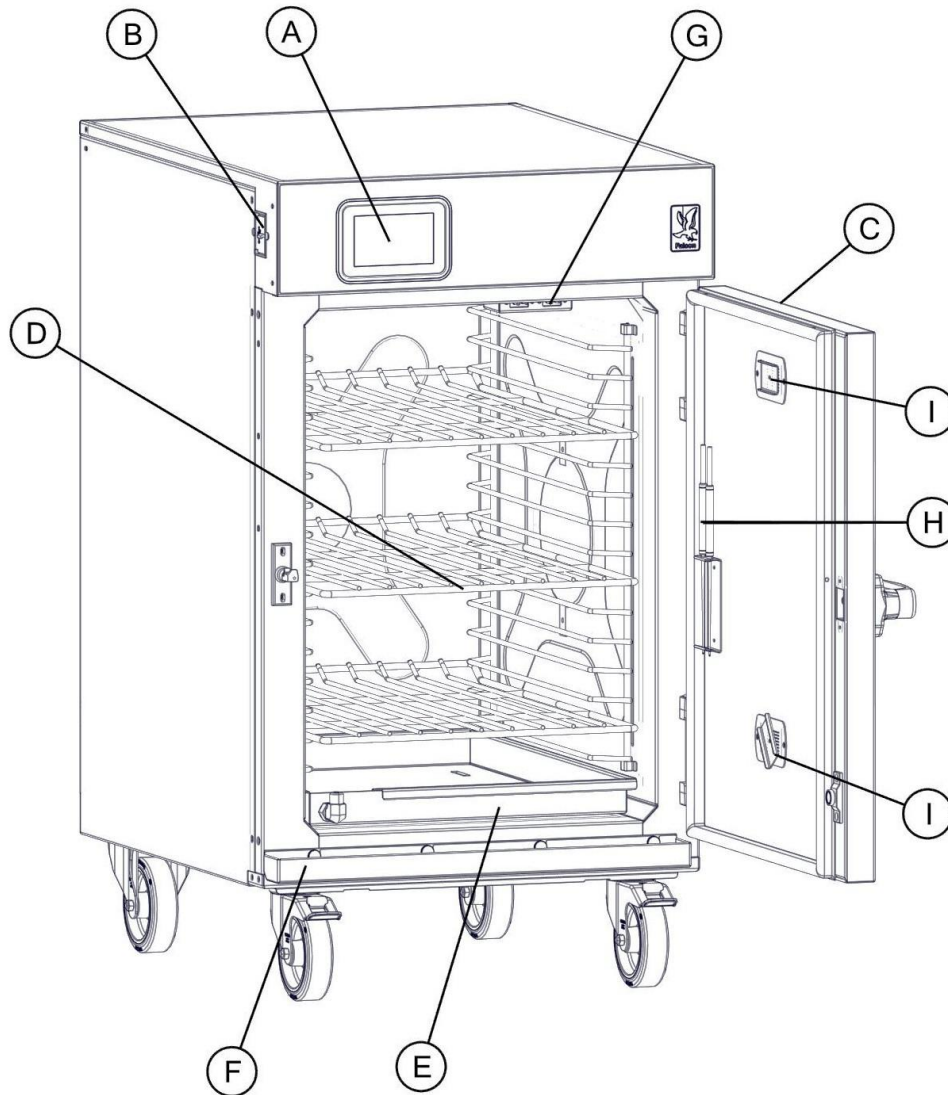

A Oven touchscreen user interface

B USB access panel

C Oven door

D *Oven shelf

E Drip tray

F Drip trough

G **Core temperature probe plug

H **Core temperature probe

I Adjustable moisture vent

*Some models are supplied with two shelves; consult your model number for specifications.

**This option is available on CH15-11P models. consult your model number for specifications.

4.2 COMPONENT PARTS CH30-11 / CH30-11P

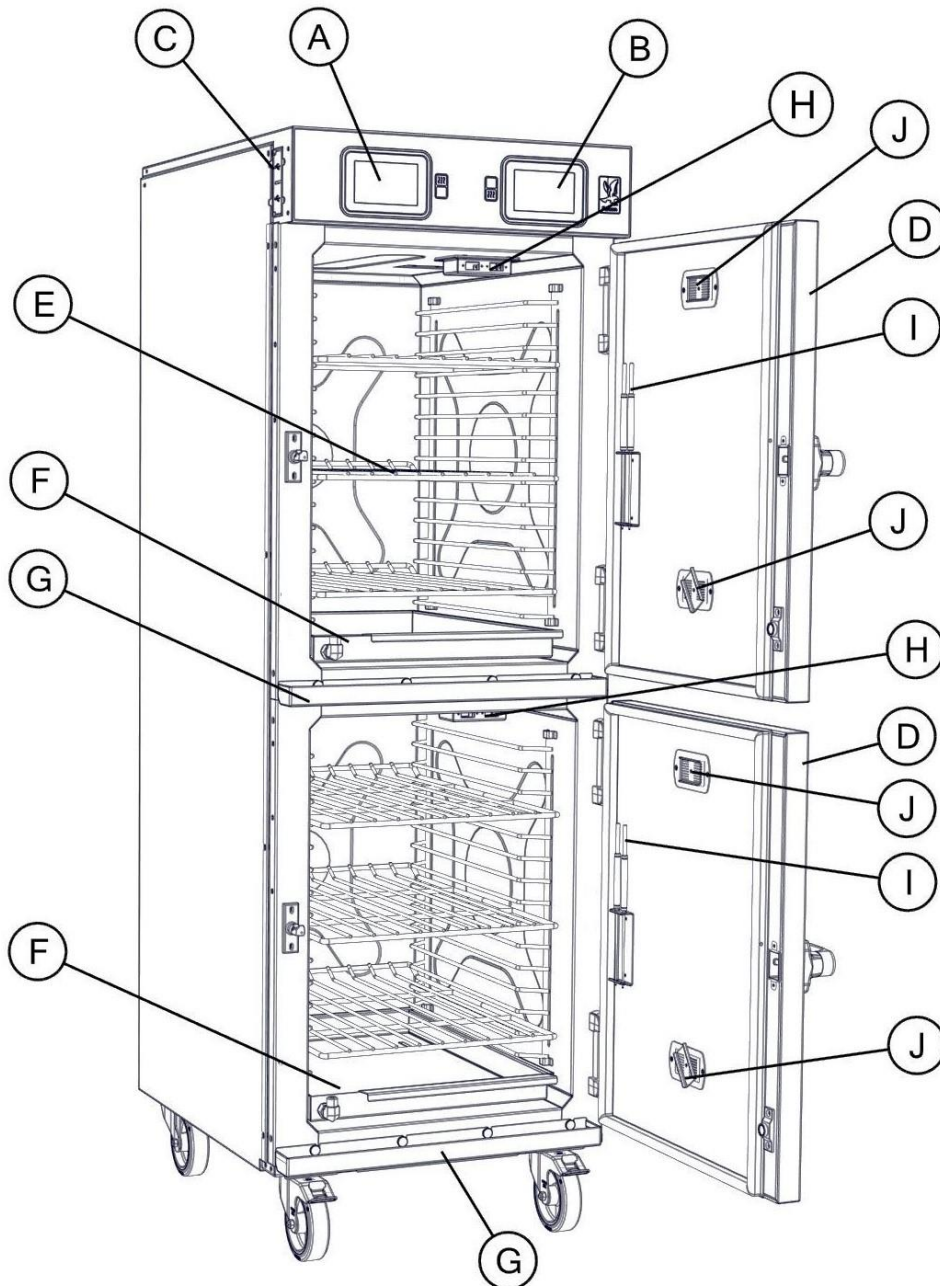

- | | | | |
|---|---------------------------------------|---|-------------------------------|
| A | Upper oven touchscreen user interface | F | Drip tray |
| B | Lower oven touchscreen user interface | G | Drip trough |
| C | USB access panel | H | **Core temperature probe plug |
| D | Oven door | I | **Core temperature probe |
| E | *Oven shelf | J | Adjustable moisture vent |

*Some models are supplied with two shelves; consult your model number for specifications.

**This option is available on CH30-11P models. consult your model number for specifications.

4.3 CONTROLS CH15-11 / CH15-11P

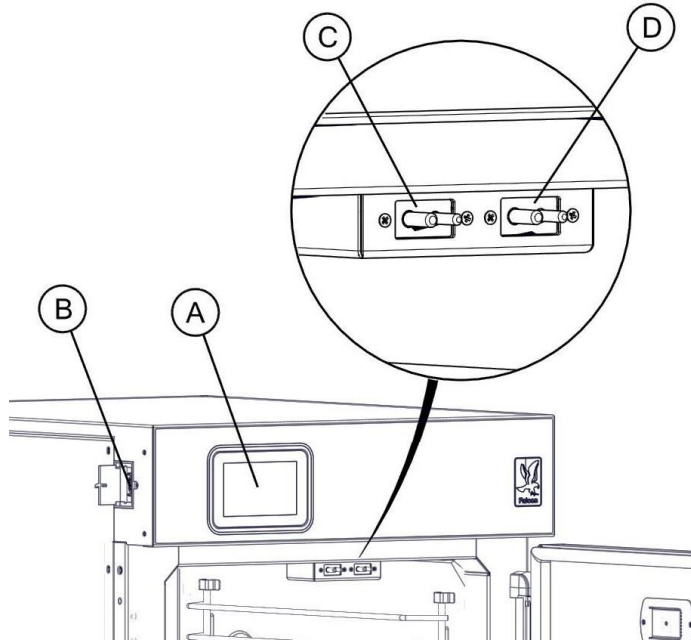

A Touchscreen user interface

B Oven USB port

C **Core temperature probe plug 1 port

D **Core temperature probe plug 2 port

**This option is available on CH15-11P models. consult your model number for specifications.

4.4 CONTROLS CH30-11 / CH30-11P

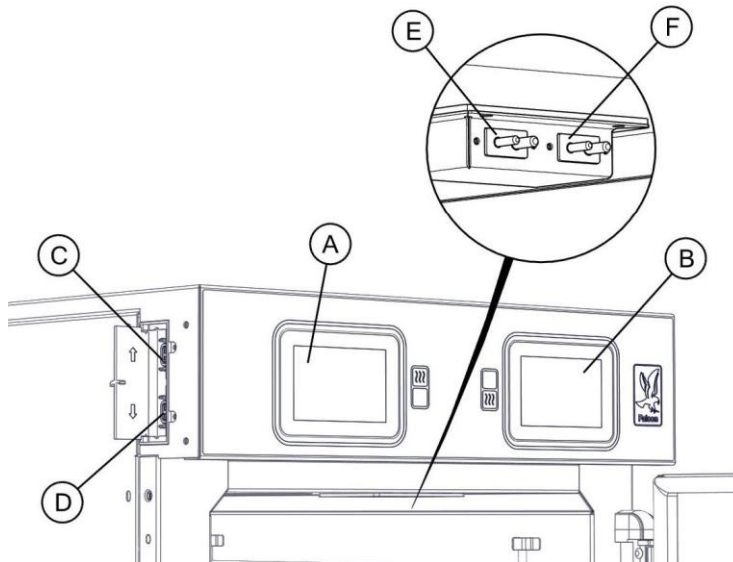

A Upper oven touchscreen user interface

B Lower oven touchscreen user interface

C Upper oven USB port

D Lower oven USB port

E **Core temperature probe plug 1 port

F **Core temperature probe plug 2 port

**This option is available on CH30-11P models. consult your model number for specifications.

4.5 OVEN CONTROL LAYOUT

The user interface for the appliance is illustrated below. Each interface operates the ovens independently, managing temperature, time, various cooking functions, etc.

- The left-side interface controls the upper oven.
- The right-side interface controls the lower oven.

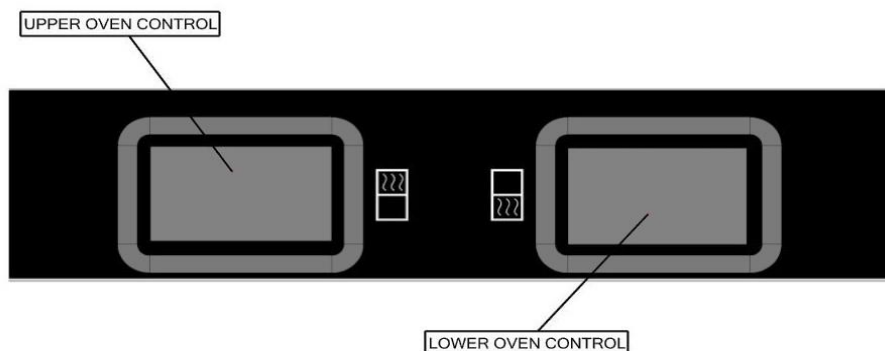

4.5 - OVEN CONTROL LAYOUT

5.0 OPERATION

Important: For detailed operation instructions, refer to section 4.0 in the user manual.

5.1 TURNING ON THE APPLIANCE

5.1.1 Plug the appliance into a suitable mains power outlet and switch on the mains power.

5.1.2 The touchscreen interface will power up and display the standby screen, as shown below.

5.1.3 Tap the Falcon logo on the screen to start up the appliance.



5.1.2 - TAP TO START

Note: Allow the controller several seconds to complete its startup sequence.

5.2 STARTING A COOK CYCLE:

Upon startup, the Home screen will be displayed automatically.

5.2.1 From the Home screen, select a cooking method from the three available cooking options:

- **Manual Cooking**
Allows the user to select and adjust preset cooking and holding cycle settings.
- **Cookbook**
Provides access to saved recipes.

- **Favourite Recipes**

Stores user defined favourite recipes for quick and convenient access.



5.2.1 - HOME SCREEN

5.2.2 When Manual Cooking is selected, the following options are available:

- Cook by Time: Set the desired cooking duration manually.
- Cook by Probe or Delta T: Monitor internal food temperature or temperature difference for precise cooking.

5.2.3 When selecting a Manual recipe or a recipe from the Cookbook or Favourite Recipes, the cooking and holding cycle parameters will be displayed for review before starting the cycle.

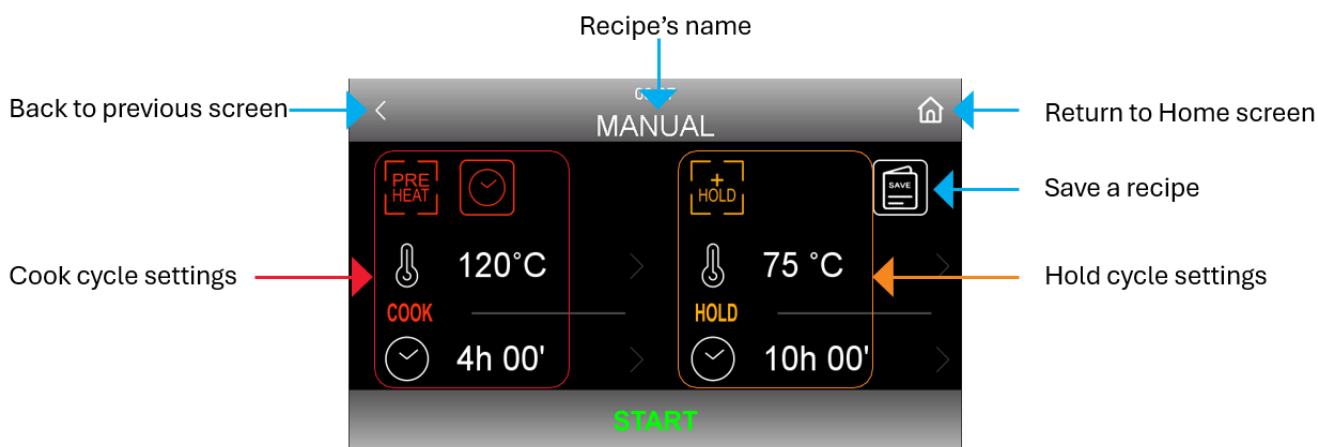

5.2.3 – Cook & Hold cycle parameters

5.2.4 Adjust the cook/hold settings if required, then press START to begin the cooking cycle.

Note: Cook/hold settings can only be adjusted in Manual Cooking. When cooking using saved recipes (from Cookbook or Favourite Recipes), the parameters are predefined and cannot be modified before starting the cycle.

5.3 STOPPING A COOKING CYCLE

You can stop the cooking process at any stage Preheat, Cooking, or Holding by following the steps below:

5.3.1 Press and hold the “STOP” icon for a few seconds to pause the cycle.

5.3.2 To cancel the cycle completely, simply touch the “STOP” icon again.

Note: Cancelling the cycle will stop all oven activity and return the system to Home Screen.



5.3.1 - PAUSE THE CYCLE



5.3.2 - CANCEL THE CYCLE

5.4 RETURNING TO THE PREVIOUS OR HOME SCREEN

For easy navigation, the control interface includes a “HOME” icon located at the top-right corner and a “BACK” icon at the top-left corner of most screens.

Note: These navigation functions are disabled during an active cooking cycle. To access them, you must first stop the current cooking operation.

5.4.1 To return directly to the Home screen, tap the “HOME” icon.

5.4.2 To return to the previous screen, tap the “BACK” icon. You may continue tapping the “BACK” icon repeatedly to navigate through previous screens until the Home screen is reached.

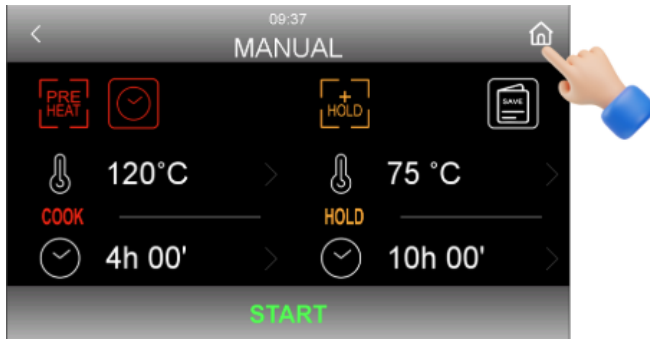

5.4.2 - QUICK ACCESS TO THE HOME SCREEN

5.5 RETURNING TO THE STANDBY SCREEN

5.5.1 Return to the home screen and tap the “BACK” Icon to the standby screen.



5.5.1 - RETURN TO STANDBY SCREEN

5.6 TURNING OFF THE UNIT

5.6.1 If the unit is in operation, first cancel the active cooking cycle.

5.6.2 Navigate the screen back to the Standby screen.

5.6.3 Once the unit is in Standby mode, switch off the power at the mains supply.

Important: Always confirm that the appliance is in Standby mode before disconnecting power to ensure safe shutdown and protect the system.

5.7 CHANGING THE DATE OR TIME

To adjust the system date and time, follow the steps below:

5.7.1 On the standby screen, tap the Settings icon (represented by a spanner symbol).

5.7.2 Select “User Configuration” from the setting menu.

5.7.3 Select “Date & Time”.



5.7.1 - SELECT SETTING

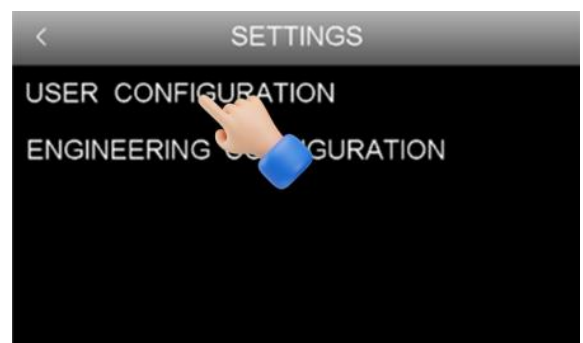

5.7.2 – USER CONFIGURATION

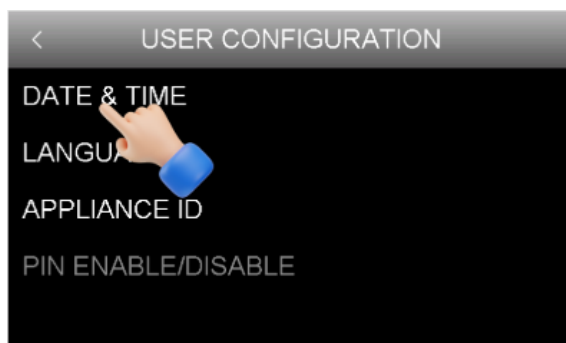

5.7.3 - SELECT “REAL TIME CLOCK”

5.7.4 Tap the date/time field, then use the slider to select the desired date/time.



5.7.4 - SELECT DATE/TIME TO CHANGE



5.7.4 - SELECT DESIRED DATE/TIME

5.7.5 Tap the updated date/time field again to confirm your selection.

5.7.6 Tap Save icon to apply the changes.



5.7.5 – CONFIRM THE SELECTION



5.7.6 - SAVE THE CHANGES

5.8 MONITORING THE ENERGY CONSUMPTION AND HEATING ELEMENT USAGE

5.8.1 To monitor energy consumption and element usage, tap the Internal values icon  during a cooking phase.

This will provide access to internal system data, including energy usage statistics for the following timeframes:

- Daily (previous 24 hours)
- Weekly (previous 7 days)
- Monthly (previous 30 days)

Note: Internal Values are displayed only accessible during an active cooking phase.



5.8.1 - ACCESS TO INTERNAL VALUES

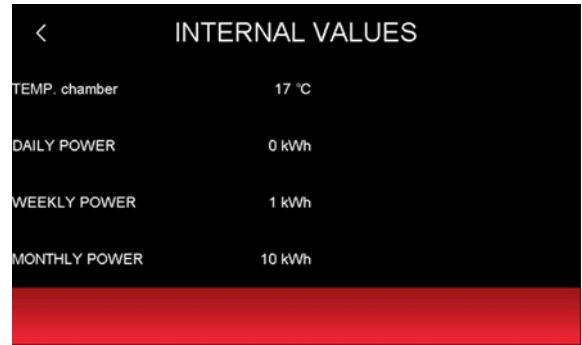

5.8.1 - VIEW THE ENERGY CONSUMPTION

5.9 USB PORT

The oven is equipped with USB port that enable the following functions:

- Download recipes to a USB drive.
- Upload recipes from a USB drive to the oven.
- Download system parameters to a USB drive (for service engineer use).
- Upload system parameters from a USB drive to the oven (for service engineer use).
- Download HACCP data to a USB drive for record-keeping and compliance.

Note: For double oven models, two USB ports are located on the left side of the control panel, one for each oven cavity. The top port corresponds to the upper oven, and the bottom port to the lower oven.

5.10 DOWNLOADING HACCP DATA VIA USB

5.10.1 Switch the unit to Standby mode (refer to Section 5.5).

5.10.2 Insert the USB key into the appropriate USB port. The controller will automatically display the USB screen.

5.10.3 Select the “HACCP Download” option.

5.10.4 Choose the desired date and time range for the HACCP data, then press Enter icon.

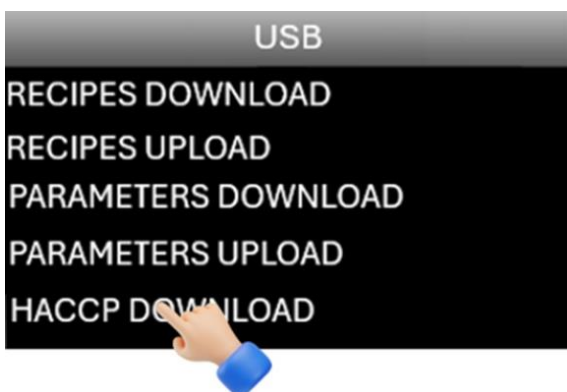

5.10.3 - SELECT HACCP DOWNLOAD



5.10.4 - SELECT THE HACCP RANGE

5.10.5 When the message “HACCP Downloaded” appears, tap the checkmark to complete the process.



5.10.4 - SELECT HACCP DOWNLOAD



5.10.5 - TAP TO COMPLETE

5.10.6 Remove the USB key to return to the Standby screen.

5.11 HOW TO DOWNLOAD /UPLOAD CONFIGURATION PARAMETERS VIA USB

5.11.1 Switch the unit to Standby mode (refer to Section 5.5).

5.11.2 Insert the USB key into the appropriate USB port. The controller will automatically display the USB screen.

5.11.3 Select the desired operation (e.g., download or upload parameters).

Note: To upload the parameters, the USB drive must contain the configuration parameters, which is downloaded to the USB drive from another machine.

5.11.4 The controller will prompt for a password. Enter -19, then tap the Enter icon .

5.11.5 Select the desired operation again (e.g., download or upload parameters).

5.11.6 To initiate the selected operation, tap the checkmark to confirm.

5.11.7 When the message (e.g. "Parameters Downloaded") appears, touch the checkmark to acknowledge and complete the process.

5.11.8 Remove the USB key. The system will automatically return to the Standby screen.



5.11.3 SELECT PARAMETER DOWNLOAD

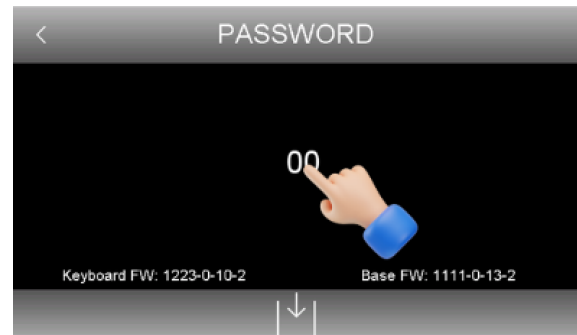

5.11.4 SELECT PASSWORD



5.11.4 SELECT PASSWORD

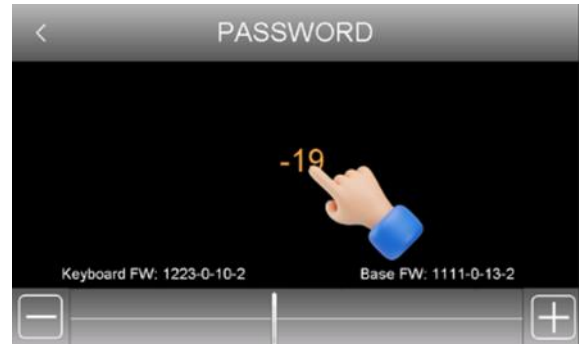

5.11.4 SELECT PASSWORD



5.11.4 SELECT PASSWORD



5.11.5 SELECT A DESIRED OPERATION



5.11.6 CONFIRM



5.11.7 COMPLETE THE PROCESS

5.12 HOW TO ACCESS/CHANGE THE CONFIGURATION PARAMETERS:

5.12.1 Tap the Spanner icon on the standby screen.

5.12.2 Select “ENGINEERING CONFIGURATION”.

5.12.3 Tap Service.

5.12.4 Tap the “00” field to open the password slider.

5.12.5 Select the password –19, then tap the password again to confirm.

- Orange indicates modification mode.
- White indicates the value is confirmed and set.

5.12.6 Tap the Enter icon  to access the configuration parameters.



5.12.1 SELECT SETTING

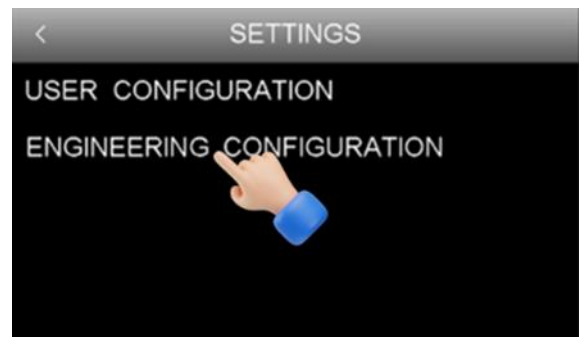

5.12.2 Select “ENG.NEER CONFIGURATION”

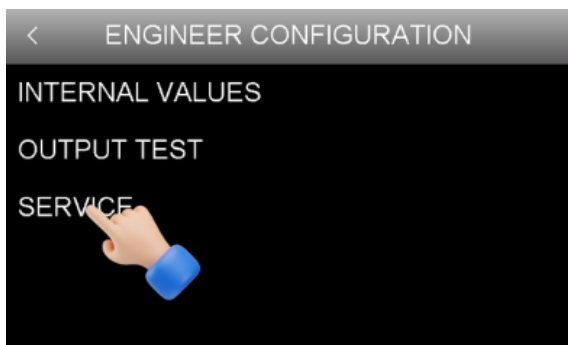

5.12.3 SELECT SERVICE

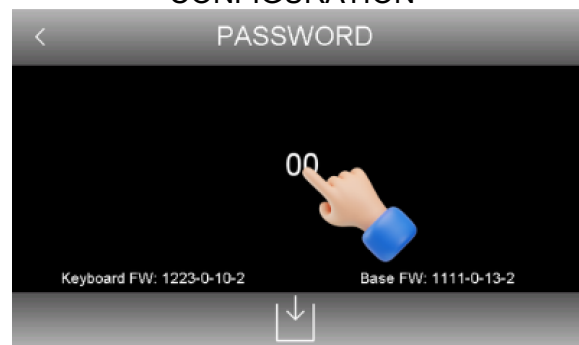

5.12.4 OPEN SLIDER

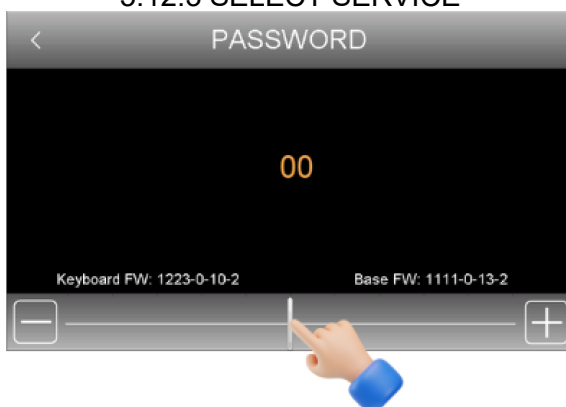

5.12.5 SELECT PASSWORD



5.12.5 CONFIRM PASSWORD



5.12.6 ACCESS PARAMETERS

5.12.7 The factory configuration parameter values are listed below. Certain parameters vary by model, including top or bottom oven configuration, single-oven units, and the presence or absence of probes.

Parameters	Label	Value	Parameters	Label	Value
Probe Type 0=J, 1= K, 2 = Pt100	P0	1	Enable Chamber Probe 2 0 = NO, 1= YES	P4	0
Measurement Unit 0=°C 1=°F	P1	0	*Chamber Probe Offset	CA1	** -9
Core Probe1 Enabling 0 = NO, 1= YES	P2	1	*Core Probe 1 Offset	CA2	-3
Core Probe 2 Enabling 0 = NO, 1= YES	P3	1	*Core Probe 2 Offset	CA3	-3

**The recommended offset value for the bottom oven is “-12”; however, minor variations may occur due to recalibration.

*The offset value may be adjusted based on the results of the calibration test.

Working Set-point Differential (°C), if r13=0	r0	1	Temp regulation type 0= On/Off 1= PI	r13	0
Minimum Set-point for Cooking	r1	70	Minimum time between two consecutive output switch-ons for temperature regulation (only valid if r13 = 1)	r14	180
Maximum Set-point for Cooking	r2	160	Minimum on/off duration of the output for temperature regulation (only valid if r13 = 1)	r15	10
Default temperature /Set-point for Cooking	r3	120	Integral time (only valid if r13 = 1), 0 = the integral time for the PI adjustment is disabled	r16	30
Core temperature minimum setpoint	r4	50	Delay message display Preheated/ Ready	r17	0
Core temperature maximum setpoint	r5	100	PREHEATING working setpoint during DELTA T cooking mode	r18	120
Core temperature working setpoint (Default)	r6	70	Differential for Booster Heater Activation	r19	1
Delta T minimum setpoint	r7	20	Differential for Booster Heater Activation Recovery (when oven door is open)	r20	1
Delta T maximum setpoint	r8	30	Working set-point for factory setting for holding	r21	75

Delta T setpoint (Default)	r9	20	Time duration for factory setting for holding phase. 0 = infinite time	r22	120
Work set-point during preheat (Cook temp + r10)	r10	0	Time duration for factory setting for cooking phase	r23	240
Work set-point during Cooling	r11	50	Minimum set-point for Holding (°C)	r24	55
Duration of a power failure during the cooking cycle sufficient to interrupt (minutes)	r12	20	Maximum set-point for Holding (°C)	r25	90

Length of time(sec) buzzer sounds on completion of the holding cycle 0 = no buzzer or pop-up -1 = until silenced manually	c0	20	Temperature above which the electronics compartment fan continues to run on entering Stand-by (referring to the operating temperature of the control module); see also F7	F6	45
Duration(sec) of buzzer sound on completion of a cooking phase 0 = no buzzer or pop-up -1 = until silenced manually	c1	2	Differential of Fan Temperature Technical Compartment (F6)	F7	1
Auto shut-off time(sec) after weekly program switch-on (when preheat enabled), if no action is taken	c2	240			
High Chamber Temperature Threshold for Locked Display (Relative to Chamber Set-point)	c3	0			
Relative to chamber probe Lower Threshold for Display Reading Lock	c4	0			

A1 Differential	A0	1	Door switch Digital Input Type 0 = normally open, when door opens 1 = normally closed, when door opens	i0	0
Max Temperature Alarm Threshold (°C)	A1	180	Type of input thermal protection fan	i1	0
Max Temperature Alarm Delay	A2	0	Safety thermal switch (Safety Stat) input type 0=normally open (input active with contact closed) 1=normally closed (input active with contact open)	i3	1
Type of Temperature Alarm 0 = alarm absent 1 = absolute (A1) 2 = relative to the working setpoint (i.e. "working setpoint + A1")	A3	1	Type of contact of the electrical absorption input (Energy Optimization System (EOS) e.g. Sicotronic System)	i4	0

High Board Temperature Alarm Threshold	A4	70			
--	----	----	--	--	--

Machine "IDENTIFIER" for downloaded HACCP file name 1= Top oven 2= Bottom oven User can change this ID, for detail see section 4.41 of User Manual	e0	1		Enable PROGRAM AGENDA functionality 0=disabled 1=enabled	e24	1
Separator for downloaded HACCP CSV FILE 0 = 'coma , ' and 1 = 'semicolon ;'	e2	0		Door open" alarm delay during a cooking cycle	e25	0
HACCP sampling time(minutes) 0=no sampling	e6	5		Enable buzzer sound for "Energy optimization" alarm 0=disabled 1=enabled	e26	0
Chamber temperature recording 0= Chamber probe HACCP temperature 1= Probe HACCP temperature displayed	e7	1		Chamber probe offset during holding	e27*	-9
Chamber temperature cooling warning band while cooking	e8	180		Duration of buzzer sound on completion of preheating phase 0 = no buzzer or pop-up -1 = until silenced manually	e28	10
Heater power consumption	e14	130		Duration of buzzer sound on reaching the first core probe temperature setpoint 0 = no buzzer -1 = until silenced manually	e29	0
Booster Heater power consumption	e15	120		Password for PIN ENABLE/DISABLE	e30	246
Zoomed Screen activation time-out	e16	15		Minimum delta oven temperature every 5 minutes for HEATING ELEMENT ISSUE signalling during preheat	e32	10
Open Door Alarm Delay(minute)	e17	1		Dynamic setpoint delta temperature for inflection point calculation during DELTA T cooking cycles	e33	30
User selection for PREHEATING phase 0=free 1=always enabled 2= always disabled	e18	0		MODBUS Address (Device address)	LA	247
User selection for HOLDING phase 0=free 1=always enabled 2= always disabled	e19	0		MODBUS Baud Rate	Lb	2

Uneven Heating Alarm Delay	e20	0	Modbus Parity	LP	2
Hysteresis for Uneven Heating Alarm	e21	1	Level 1 Connectivity (Epoca) Password	PA1	426
Threshold for Uneven Heating Alarm	e22	100	Level 2 Connectivity (Epoca) Password	PA2	824
Threshold for Display Lock (Low Temperature)	e23	10	serial port configuration for connectivity 0=free for MODBUS RTU 1-99 = EPoCA local network address N.B: if connectivity comes from EVlinking Wi-Fi, the only value that can be set is 1	BLE	1

*The offset value may be adjusted based on the results of the calibration test.

5.13 LIST OF PASSWORDS

(Used in ENGINEERING CONFIGURATION page, see section 5.13.1 to 5.13.3):

- Access Configuration Parameters: Tap SERVICE and enter **-19**
 - Access Internal Values (e.g. Board temperature): Enter **19**
 - Access Output Test: Enter **20**
 - Reset Total Element Usage and Energy Consumption Counters: Enter **21**
- Note: For monitoring element usage and energy consumption, refer to Section 5.9.

6.0 MAINTENANCE AND SAFETY CHECKS

When removing heavy items to aid maintenance particular care should be taken. A manual handling risk assessment is the best way to determine the level of risk to anyone using or maintaining this equipment. To help with such an evaluation we have included the weights of individual components that may present significant risk.

For further help and information on manual handling and associated risk assessment, we would refer you to the Health and Safety Executive website; www.hse.gov.uk document ref: manual handling at work INDG143. International customers should default to the health and safety guidelines provided by your government body.

Other useful references for health and safety issues:

- www.hse.gov.uk
- Essentials of health and safety at work ISBN978
- Noise at work INDG362
- Safe systems of work
- Other notes added to the body of the instructions.

6.1 MAINTENANCE CHECKS

REGULAR SERVICING OF THE APPLIANCE SHOULD BE UNDERTAKEN TO ENSURE CORRECT OPERATION, IT IS FUNCTIONING AS INTENDED, AND SAFE TO USE. WE RECOMMEND SERVICING AFTER 2,500 HOURS OF USE, OR ANNUALLY, WHICHEVER COMES FIRST.



ANY MAINTENANCE SCHEDULE SHOULD BE CARRIED OUT IN ACCORDANCE WITH SFG20 MAINTENANCE SCHEDULE. SHOULD ANY ISSUES WITH THE INTEGRITY OF THE COMPONENTS BE IDENTIFIED THESE SHOULD BE REPLACED. IF THE APPLIANCE IS NOT CONSIDERED SAFE THE UNIT SHOULD BE REMOVED FROM SERVICE AND THE RESPONSIBLE PERSON ADVISED WHY THE UNIT IS NOT SAFE TO USE AND WHAT REMEDIAL ACTION IS NEEDED. CONTENTS OF THE MAINTENANCE SCHEDULE SHOULD BE AGREED WITH THE MAINTENANCE PROVIDER.

NOTE – Cable Replacement:

For single-phase appliances in the event of the main cable being replaced, a cable conforming to the code designation EN 50525-2-21 or IEC 60245-4 (such as H07RN-F 3G2.5) must be used for connection for Single Phase Units to a 230V 1N~ supply.

For three-phase appliances in the event of the main cable being replaced, a cable conforming to code designation EN 50525-2-21 or IEC 60245-4 (such as H07RN-F 5G1.5) must be used for connection for Three Phase Units to a 400V 3N~ supply.

Only use Falcon-approved spare parts. When ordering spare parts, please quote the model number; serial number stated. This information will be found on the data plate attached to the appliance's rear.

6.2 MAINTENANCE

Item / Component	Inspection Task	Inspection Type
Cooling Fan	Inspect cooling fan for proper operation and airflow.	Visual / Functional
Operating Thermostat	Verify correct thermostat function and temperature cycling.	Functional
Core Probes (if applicable)	Inspect probes for damage, kinks, and cleanliness.	Visual
Core Probe Connector (if applicable)	Check connector for secure fit, corrosion, or bent pins.	Visual / Technical
Core Probe Mounting/Assembly	Inspect mounting for stability and proper alignment.	Visual
Wiring in Control Box	Check all wiring connections for looseness or heat discoloration.	Visual / Technical
Oven Load Current	Measure load current during operation and compare to specifications.	Technical
Door Gasket	Inspect gasket for cracks, or heat damage.	Visual
Louver Panel (Control Box Rear)	Remove and clean louver panel to ensure airflow.	Cleaning / Visual
Door Vent Openings	Inspect vent openings and clear blockages.	Visual
Power Mains Cable	Inspect cable for cuts, abrasions, or heat damage.	Visual
Outer Panels	Check for corrosion, dents, or structural damage.	Visual
Door Switch	Check proper operation	Functional
Drip Tray Drain	Inspect drain for blockages and proper flow.	Visual / Cleaning
Front Frame Behind Drip Trough	Inspect for corrosion, debris, leakage and structural wear.	Visual
Oven Casters	Inspect casters for wear or damage; ensure they roll freely.	Visual / Functional
Oven Stability	Verify oven is level and stable; check for wobbling or uneven weight distribution.	Functional / Visual

7.0 SPECIFICATION

7.1 APPLIANCE WEIGHT TABLE

APPLIANCE	UNIT WEIGHT (kg)	PACKED WEIGHT (kg)
CH15-11/ CH15-11P	140	155
CH30-11/ CH30-11P	235	250

7.2 TECHNICAL DATA TABLE(S):

MODEL: CH15-11 & CH15-11P (230 V 1N~ SINGLE PHASE SUPPLY)

	PHASE	CURRENT			POWER
		MIN (A)	MAX (A)	ACTUAL (A)	(kW)
TOTAL	L1	9.9	11.55	11	2.5

MODEL: CH30-11 & CH30-11P (230 V 1N~ SINGLE PHASE SUPPLY)

	PHASE	CURRENT			POWER
		MIN (A)	MAX (A)	ACTUAL (A)	(kW)
TOTAL	L1	19.80	23.10	22	5
EACH OVEN	L1	9.9	11.55	11	2.5

MODEL: CH30-11 & CH30-11P (400 V 3N~ THREE PHASE SUPPLY)

	PHASE	CURRENT			POWER
		MIN (A)	MAX (A)	ACTUAL (A)	(kW)
CONTROL CIRCUIT	L1			≈ 0.15*	
TOP OVEN	L2	9.9	11.55	11	2.5
BOTTOM OVEN	L3	9.9	11.55	11	2.5

*≈ 0.26 A with one cooling fan running

*≈ 0.37 A if both cooling fans are on

Note: This unit is equipped with a Smart Heating Control system designed to optimize energy consumption while maintaining precise temperature control.

When the oven temperature is within 1°C below the setpoint, a single heater circuit is activated, reducing power by up to 50%. So, if the current measured during this time the current range would be 5.5A to 6.5A.



IF ANY CURRENT IS OUT WITH THESE TOLERANCES, THE CAUSE MUST BE INVESTIGATED AND RECTIFIED.

8.0 DIMENSIONS

8.1 CH15-11 / CH15-11P SINGLE OVEN

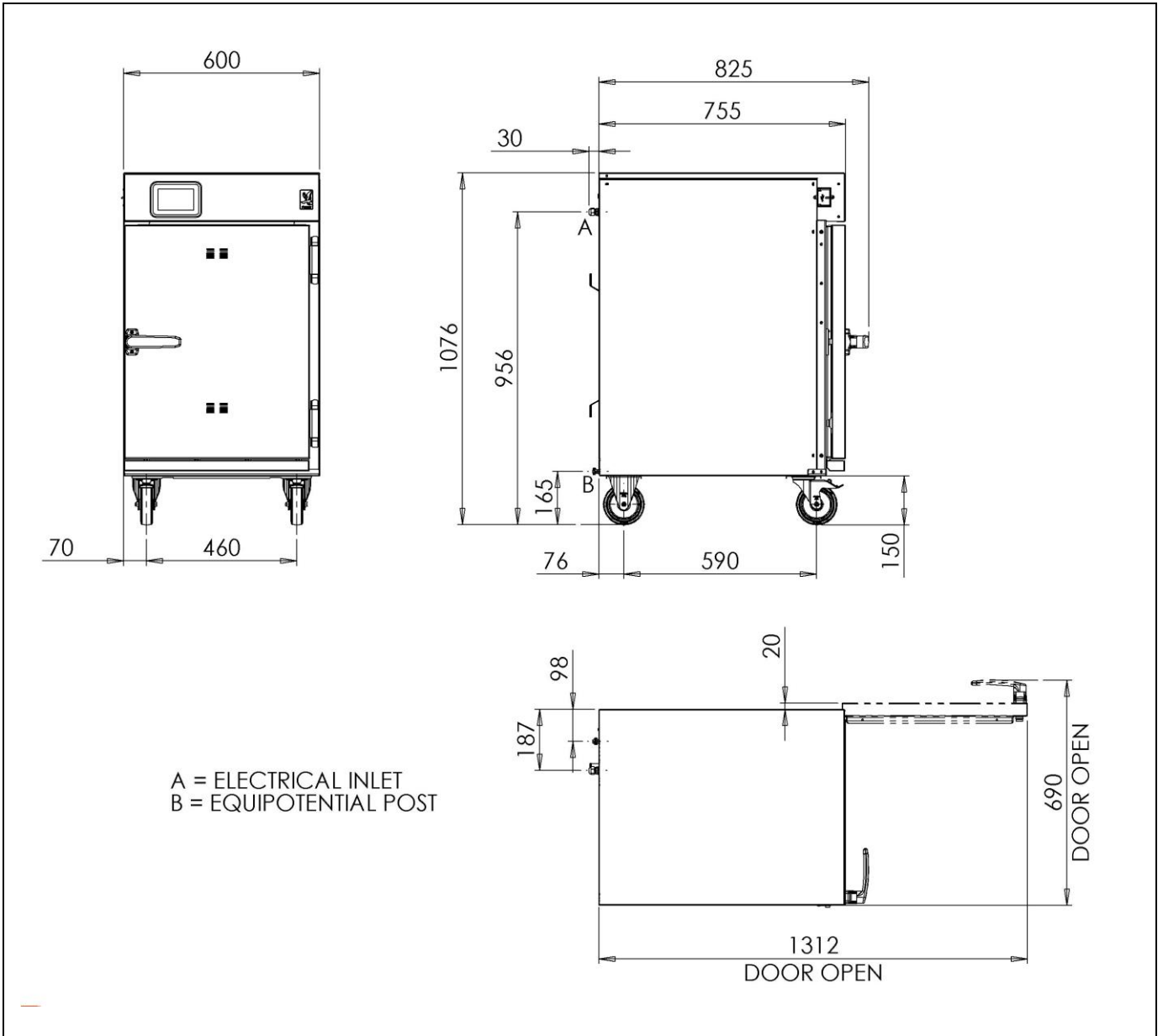

8.2 CH30-11 / CH30-11P DOUBLE OVEN

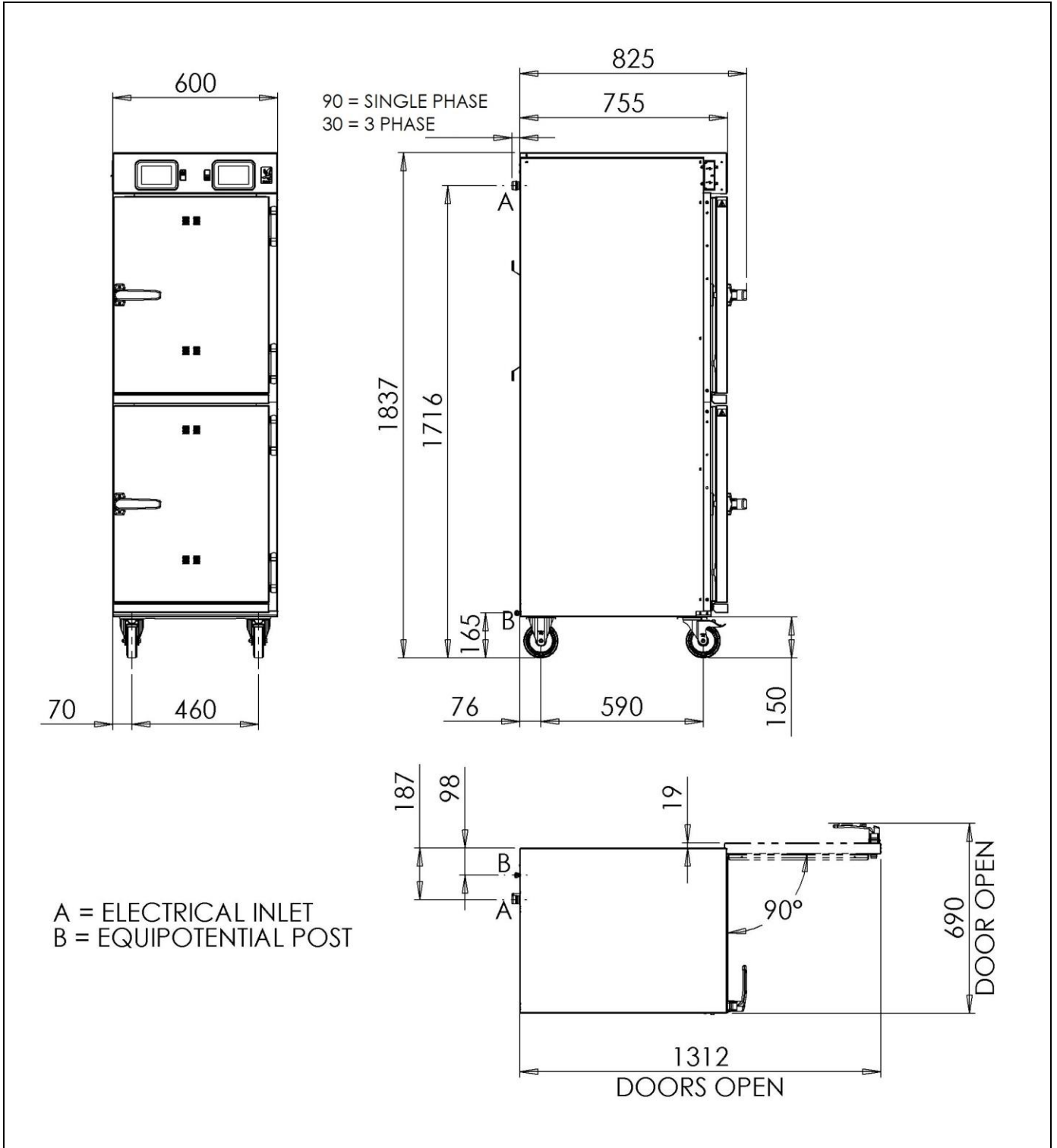

9.0 INSTALL, POSITIONING, CLEARANCES, POWER & CALIBRATION

ALWAYS COMPLY WITH YOUR LOCAL MANUAL HANDLING AND HEALTH AND SAFETY REGULATIONS WHEN MOVING OR REPOSITIONING THE OVEN.



THE MANUFACTURER CANNOT BE HELD RESPONSIBLE FOR INJURIES, DAMAGES, OR ACCIDENTS RESULTING FROM IMPROPER HANDLING, REPOSITIONING, OR USE OF INADEQUATE EQUIPMENT.

CARE MUST BE TAKEN WHILST HANDLING SHEET METAL.

REFER TO SECTIONS 2.2 & 2.3 FOR ELECTRICAL SAFETY GUIDELINES

9.1 POSITIONING

Follow the steps / guidelines below to safely move / position the unit:

- 9.1.1** Make sure you have an appropriate lifting device and a sufficient number of trained personnel to safely move and position the oven based on its weight and size.
- 9.1.2** The oven is heavy and may cause serious injury if it overturns.
- 9.1.3** Danger of crushing due to the appliance overturning on persons.
- 9.1.4** Take care of the centre of gravity of the appliance.
- 9.1.5** Take great care to ensure that the appliance does not overturn during moving.
- 9.1.6** Use PPE such as safety footwear and gloves if moving the oven requires significant effort or presents injury risk.
- 9.1.7** Ensure the path is clear of obstacles and debris.
- 9.1.8** Ensure that the floor can safely support the oven's weight.
- 9.1.9** Check access dimensions (doorways, corridors). For passages under 800mm, remove detachable parts (i.e. handles) to avoid damage.
- 9.1.10** Push the oven slowly and steadily from a stable point using both hands. Avoid sudden or forceful movements and never make sharp turns.
- 9.1.11** Only move the oven on flat, even surfaces. Uneven or sloped floors increase the risk of tipping or uncontrolled movement.
- 9.1.12** Do not stretch, kink, or place strain on power cables.
- 9.1.13** Maintain adequate clearance for safe operation and ventilation. Minimum clearance requirements are specified in Sections 9.2.
- 9.1.14** Position the appliance on stable and level floor.
- 9.1.15** Once in position, engage caster brakes to prevent accidental movement.
- 9.1.16** Visually inspect the appliance to ensure no components were dislodged or damaged during movement.
- 9.1.17** Inspect the mains cable and plug positioning.

9.2 POSITIONING CLEARANCES



POSITION THE APPLIANCE ON A STABLE AND LEVEL FLOOR.

DO NOT INSTALL THIS APPLIANCE IN ANY AREA WHERE IT MAY BE SUBJECTED TO DRAUGHTS OR ANY OTHER ADVERSE CONDITIONS.



DO NOT INSTALL A COOK AND HOLD OVEN NEXT TO THE FRYER. MAINTAIN A MINIMUM CLEARANCE OF 1 m BETWEEN THE FRYER AND ANY COOK AND HOLD OVEN.

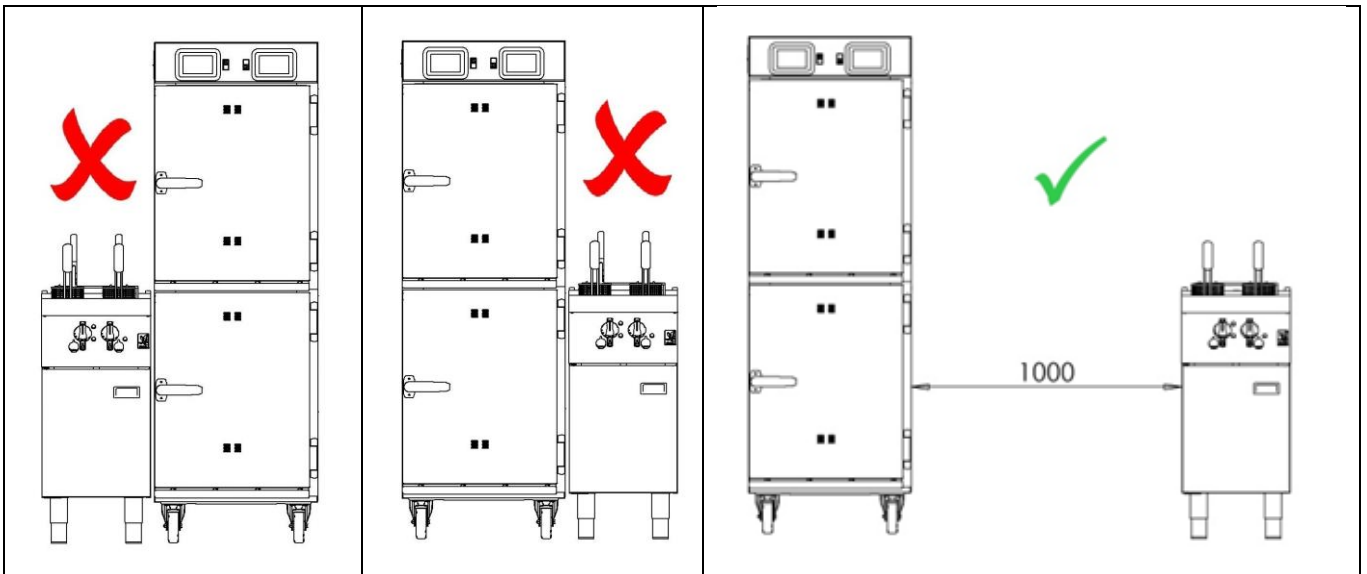

MAINTAIN A MINIMUM CLEARANCE OF 75 mm BETWEEN COOK AND HOLD APPLIANCES OR BETWEEN THE APPLIANCE AND ANY OTHER SOURCE OF HEAT.

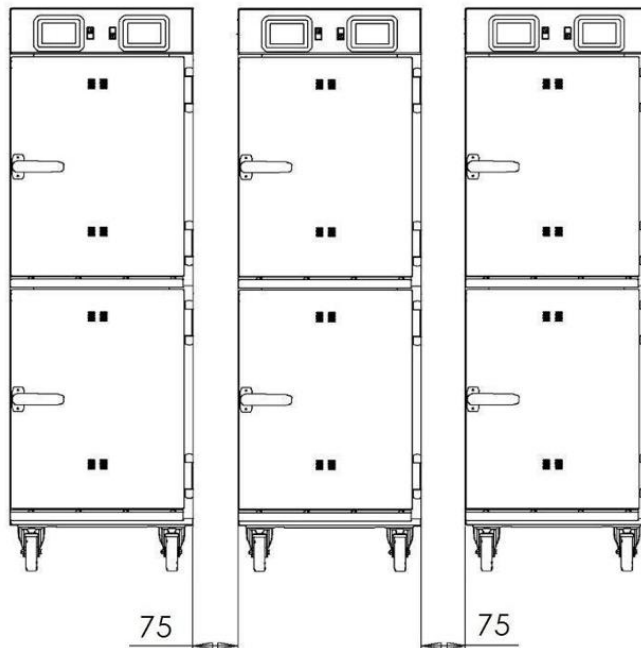

This appliance must be installed on a level floor in a well-lit position. Ensure a minimum clearance of 150 mm at the rear and top, and 75 mm on each side for both combustible and non-combustible walls. It is important for adequate ventilation for the unit from all sides.

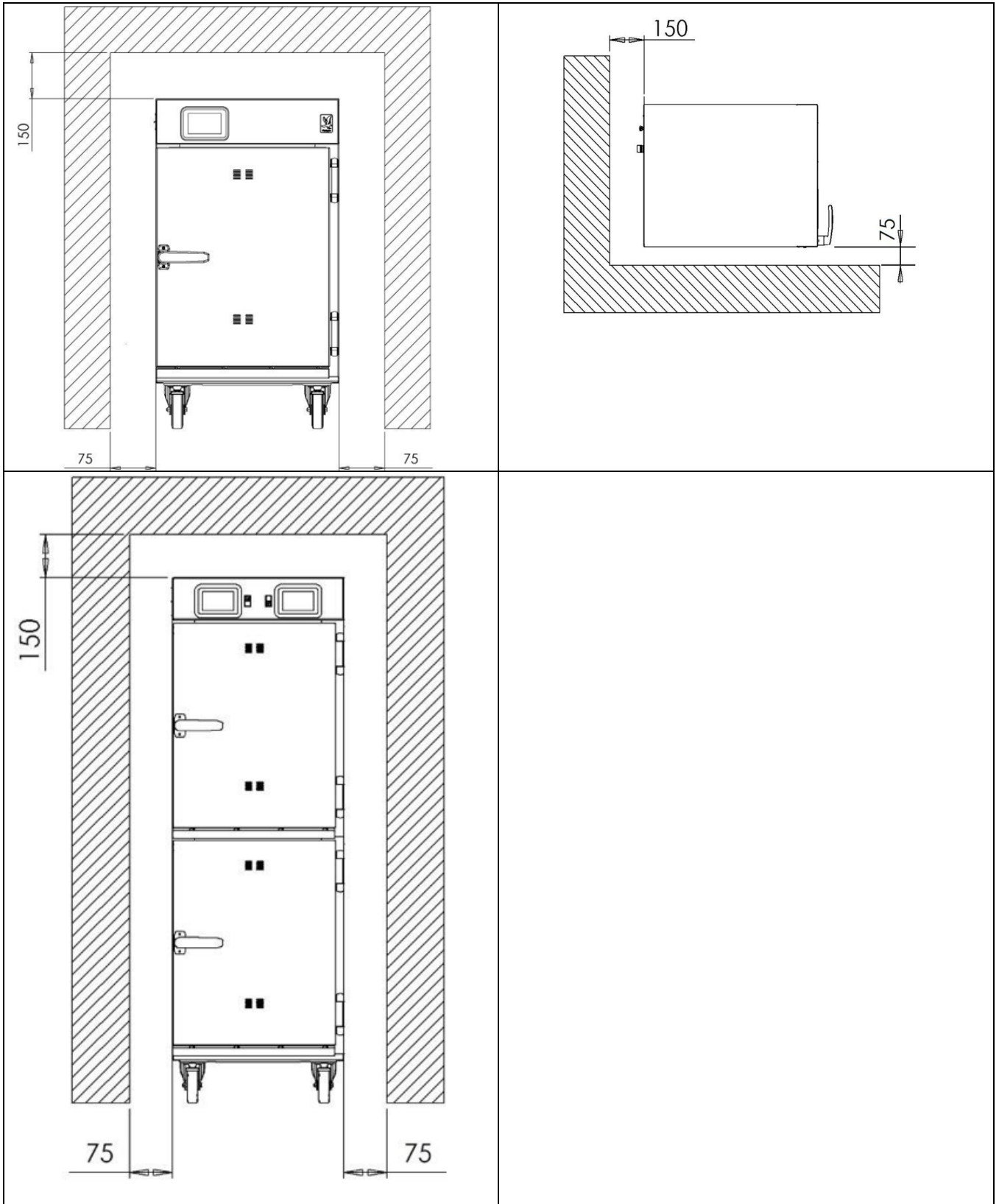

9.3 ELECTRIC SUPPLY & CONNECTION



WARNING:

All electrical installation work must be carried out by qualified and authorised personnel.
Installation must comply with all applicable national or local regulations.
Disconnect the appliance from the mains before performing any service or installation work.

General Information

- The appliance is supplied with a factory-fitted mains cable.
- The electrical mains cable entry point is shown below.
- This appliance is designed exclusively for AC power supply.

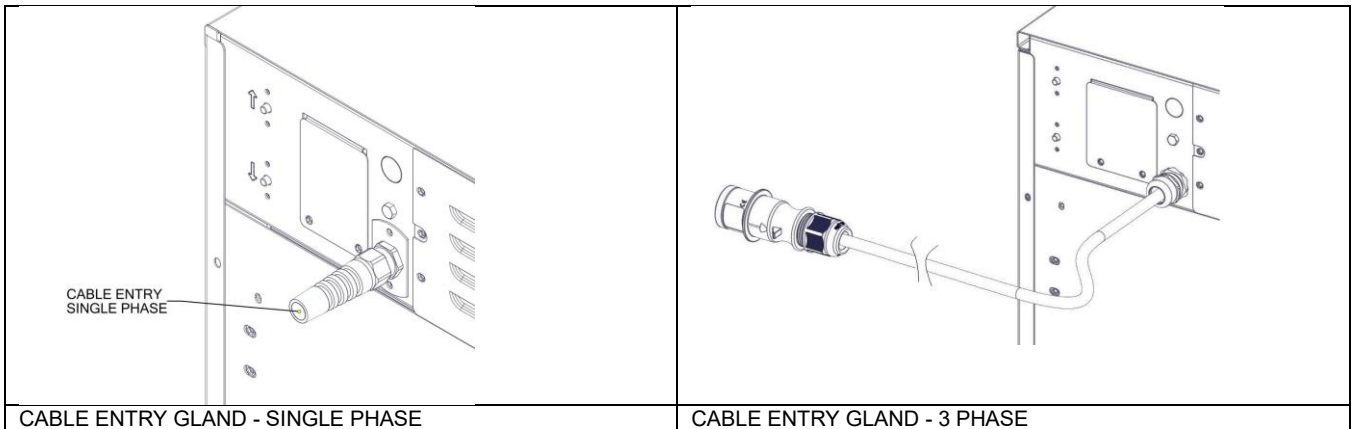

Terminal configurations:

- 230 V, 1N~ (single phase units)
- 400 V, 3N~ (three phase units)

Factory-Supplied Power Connections

For Double oven:

- Single-phase units (230 V, 1N~) are supplied with a 2.5 m, 3-core, 2.5 mm² mains cable, fitted with a 32 A single-phase Commando plug.
- Three-phase units (400 V, 3N~) are supplied with a 2.5 m, 5-core, 1.5 mm² mains cable, fitted with a 16 A three-phase Commando plug.

For single oven:

- Single-phase units (230 V, 1N~) are supplied with a 2.5 m, 3-core, 1.5 mm² mains cable, fitted with a 13A plug.



THIS APPLIANCE MUST BE EARTHED

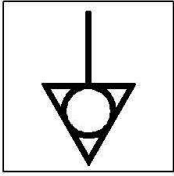

This appliance is also provided with a terminal for connection of an external equipotential conductor. This terminal is an effective electrical contact with all fixed exposed metal parts of the appliance and shall allow the connection of the conductor having a nominal cross-section area of up to 10mm². It is located at the rear of the unit and identified by the following label and must only be used for bonding purposes.

NOTE

In the event of the main cable being replaced, a cable conforming to the code designation EN 50525-2-21 or IEC 60245-4 (such as H07RN-F) must be used for connection for Single Phase Units to a 230V 1N~ supply or for Three Phase Units to a 400V 3N~ supply.

Only use Falcon-approved spare parts. When ordering spare parts, please quote the model number; serial number stated. This information will be found on the data plate attached to the appliance's rear.

9.4 OVEN CALIBRATION:

Calibrate the oven cavity by doing following steps:

Note: For dual ovens, perform calibration on both units simultaneously.

- Ensure the oven is clean and empty. Inspect the temperature sensor (Op-stat) to ensure it is clean and in good condition.
- Place the oven in an environment with stable ambient temperature conditions.
- Insert a calibrated thermocouple into the centre of the oven cavity, ensuring the oven drip tray is in place.

Calibrate the oven during Hold mode:

- Program the oven to 75 °C in HOLD mode.

To operate the oven in Holding Mode only, bypass the Cook or Preheat cycle. Tap the Cook (Time) icon and confirm to disable the cooking function. For detailed instructions, refer to Section 4.10 of the User Manual.

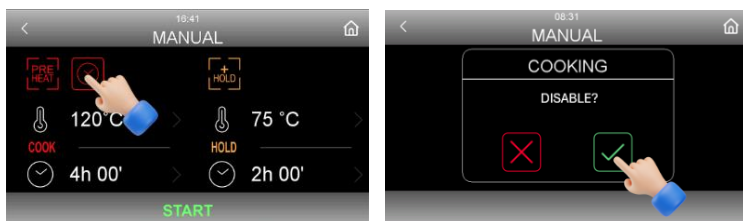

- Start the oven and allow some time to oven heat up to set temperature and temperature stabilization.
- Do not open the oven door during this period.
- Measure and record the oven temperature using a calibrated thermometer.
- Take the measurement after the initial temperature overshoot, once the oven temperature has settled back to the 75 °C setpoint. The temperature stabilization process will take approximately one hour.
- Verify that the measured temperature is within the specified tolerance of the setpoint (75 °C): -2 °C / +2 °C.
- If the temperature is outside the allowable tolerance, continue operating the oven for an additional 5 to 10 minutes and verify that the measured temperature is within the specified tolerance.
- If the temperature remains outside the allowable tolerance, adjust the chamber probe offset by modifying parameter (for the HOLD phase) e27. Make the necessary adjustment, then repeat the temperature measurement. Refer to Section 5.13 for instructions on accessing the configuration parameters.

Calibrate the oven during Cook mode:

Note: For dual ovens, perform calibration on both units simultaneously.

- Ensure that calibration of the HOLD phase has been successfully completed before proceeding.
- Program the oven to 120 °C in COOK mode.
- Start the oven and allow a minimum of 45 minutes for preheating and temperature stabilization. Do not open the oven door during this period.
- Measure and record the oven temperature using a calibrated thermometer.
- Verify that the measured temperature is within the specified tolerance of the setpoint (120 °C): -5 °C / +0 °C.
- If the temperature is outside the allowable tolerance, continue operating the oven for an additional 30 minutes. Then re-measure and verify that the temperature is within the tighter tolerance of -2 °C / +0 °C for the upper oven and -2 °C / +2 °C for the lower oven.

- If the temperature remains outside the allowable tolerance, adjust the chamber probe offset by modifying parameter **CA1** for the COOK phase. Make the necessary adjustment, then repeat the temperature measurement. Refer to Section 5.13 for instructions on accessing the configuration parameters.
- Record all temperature readings and calibration adjustments in the calibration log.

For significant temperature deviations, perform the following actions:

- Confirm proper operation of the heating elements by comparing the measured load current against the specifications in Section 7.
- Inspect the temperature sensor (Op-stat) to ensure it is clean and in good condition.

Note: Please note that the lower oven cavity may initially register a slightly higher temperature than the upper oven cavity. This condition is normal. After a period of operation, the temperatures will stabilize and balance relative to the upper oven cavity.



PLEASE FILL OUT THE INFORMATION TABLE ON THE FRONT COVER AFTER COMMISSIONING

9.5 CALIBRATE OF THE CORE PROBES (IF THE UNIT IS EQUIPPED WITH PROBES.)

Calibrate the oven cavity by doing following steps:

- Connect the core probes into the oven's probes connector.
- Remove the probes from the oven cavity and close the oven door.
- Run the cooking cycle using Manual Cook (Time) mode.
- Tap the Probe 1 and Probe 2 icons located at the top left-hand (LH) and right-hand (RH) sides of the screen, respectively, to display the temperature readings for each probe.

Note: After connecting a probe, the controller requires approximately 1 minute to display the temperature once the reading has stabilized.

- Fill a suitable container with boiling water.
- Immerse the top oven core probes along with a calibrated reference thermocouple into the hot water.

Note: Ensure all sensing tips are fully immersed and not in contact with the sides or bottom of the container.

- Allow 1–2 minutes for the temperature readings to stabilize.
- Record the temperatures shown by both the core probes and the reference calibrated thermocouple.
- Repeat this procedure for the bottom oven.
- Verify that each core probe reading is within $+0 / -1$ °C of the reference temperature.
- Apply the appropriate offset correction based on the observed deviation.

Core probe offset configuration parameters:

CA2 — Probe 1

CA3 — Probe 2

- Refer to Section 5.13 for instructions on accessing the configuration parameters.
- After adjustment, repeat the hot water test to confirm improved accuracy.

If the appliance does not operate correctly, please refer to Sections 11 and 12 for troubleshooting and corrective actions.

10.0 SERVICING



BEFORE ATTEMPTING ANY MAINTENANCE, ISOLATE THE APPLIANCE AT THE MAINS SWITCH AND TAKE STEPS TO ENSURE THAT IT IS NOT INADVERTENTLY SWITCHED ON.

10.1 THERMOCOUPLE REPLACEMENT

10.1.1 Remove the cover as described in section 10.5.

10.1.2 Remove the left-hand side panel as described in section 10.8.

10.1.3 Detach relevant operating thermocouple cables from the Insulation and I/O power board.

10.1.4 Remove the fixings from the thermocouple housing and drop it down.

10.1.5 Use one spanner to hold the inner thermocouple nut and a second spanner to loosen the outer nut.

10.1.6 Withdraw the thermocouple wire completely.

10.1.7 Install the new thermocouple, tightening the mounting nut in the housing as originally mounted.

10.1.8 Feed the wire through the inlet, route it as per the original installation, and secure the housing by tightening its fixings.

10.1.9 When re-fitting thermocouple, ensure all electrical connections are restored as detailed in the wiring diagram.

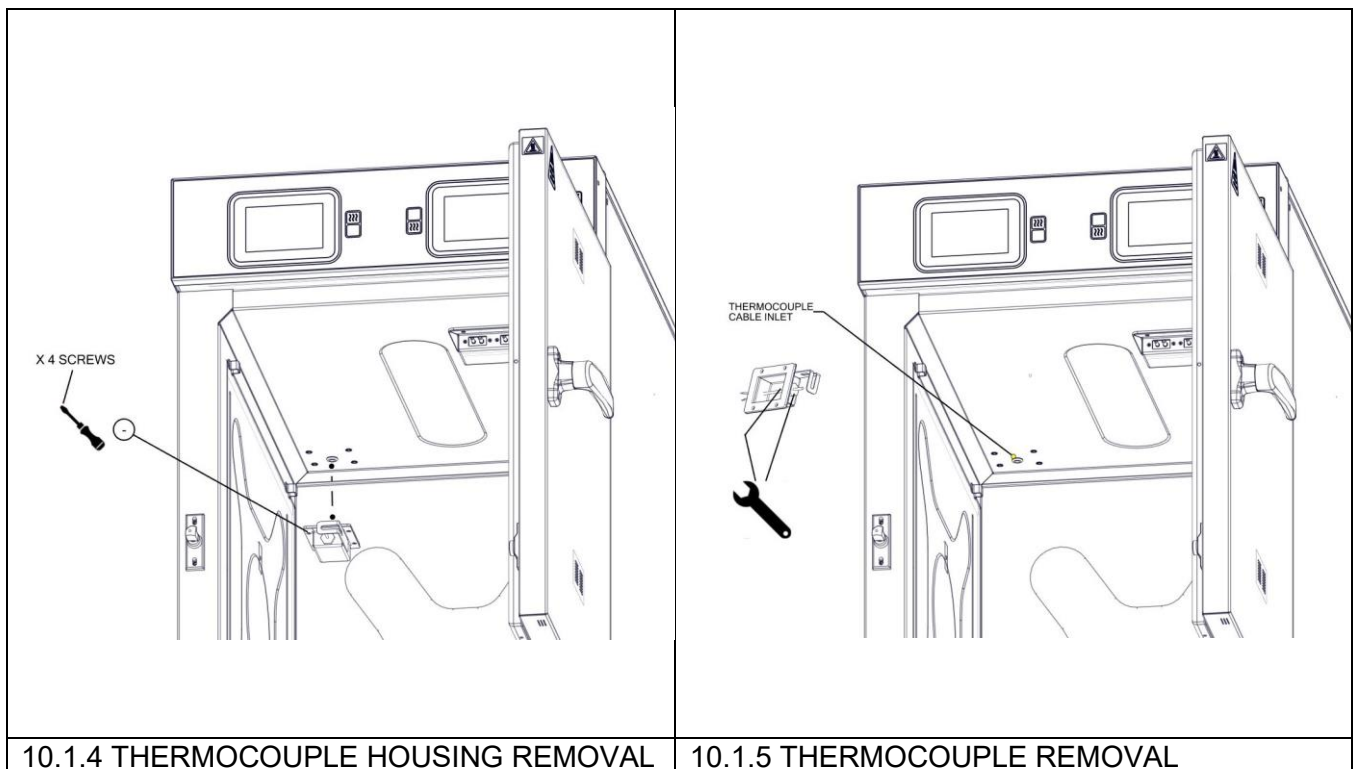

10.2 OVEN SAFETY THERMOSTAT RESET



WARNING:
IF A SAFETY TRIP HAS BEEN ACTIVATED, THE REASON FOR OVERHEATING MUST BE IDENTIFIED BEFORE RETURNING THE APPLIANCE TO SERVICE.

10.2.1 If the oven safety thermostat has tripped, refer to sections 11 and 12 for diagnosis and rectification before resetting.

10.2.2 An overheat safety trip is fitted to the oven(s). Access is on the rear upper side of the appliance as shown below. To reset, press the button.

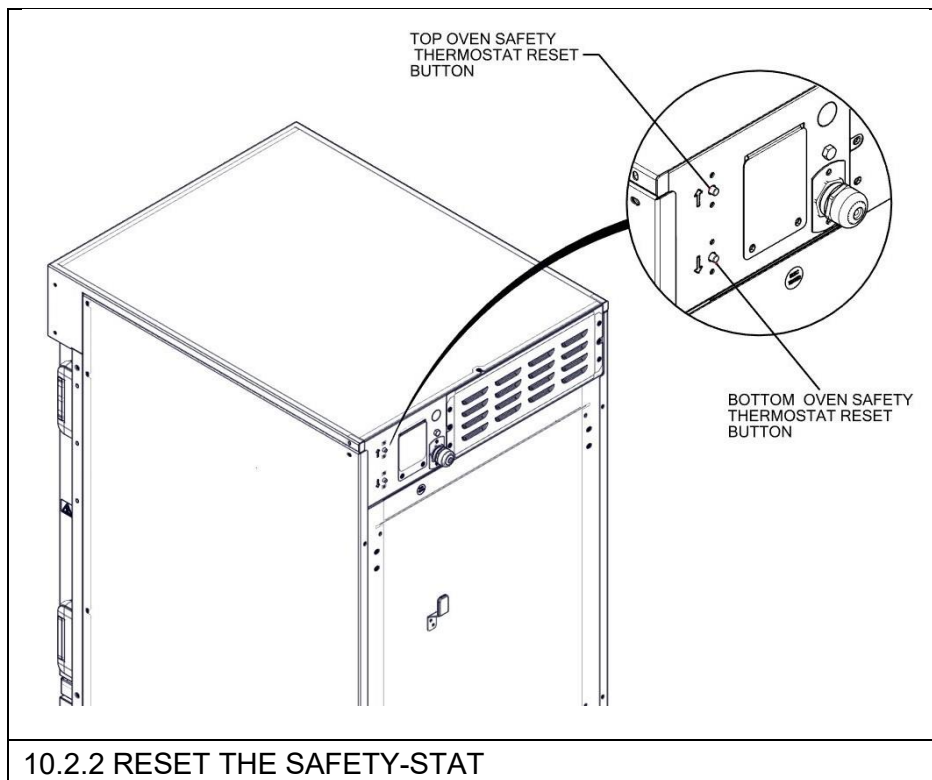

10.3 OVEN SAFETY THERMOSTAT REPLACEMENT



BEFORE ATTEMPTING ANY MAINTENANCE, ISOLATE THE APPLIANCE AT THE MAINS SWITCH AND TAKE STEPS TO ENSURE THAT IT IS NOT INADVERTENTLY SWITCHED ON.

10.3.1 Remove the cover as described in section 10.5.

10.3.2 Remove the right-hand side panel as described in section 10.8.

10.3.3 Disconnect the wiring from the relevant safety thermostat terminals.

10.3.4 Remove fixings from the relevant safety thermostat.

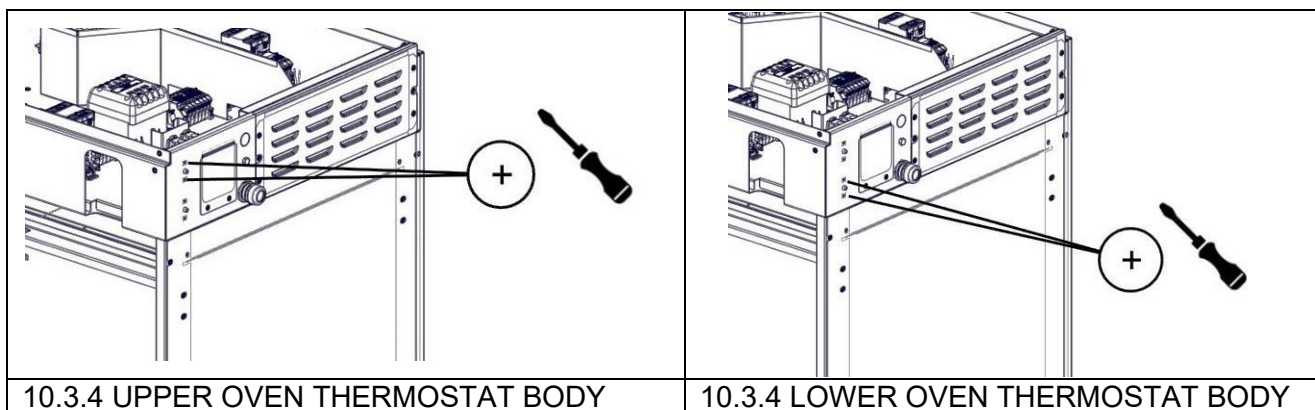

10.3.5 Remove fixings from the relevant safety thermostat phial retaining plate.

10.3.6 Remove the relevant safety thermostat phial. Carefully withdraw the capillary tube and remove the thermostat assembly from the appliance.

10.3.7 If the capillary tube is protected with Vidaflex, transfer it from the old thermostat to the new thermostat.

10.3.8 Install the new thermostat assembly by reversing the removal procedure.

10.3.9 When re-fitting, ensure all electrical connections are restored as detailed in the wiring diagram.

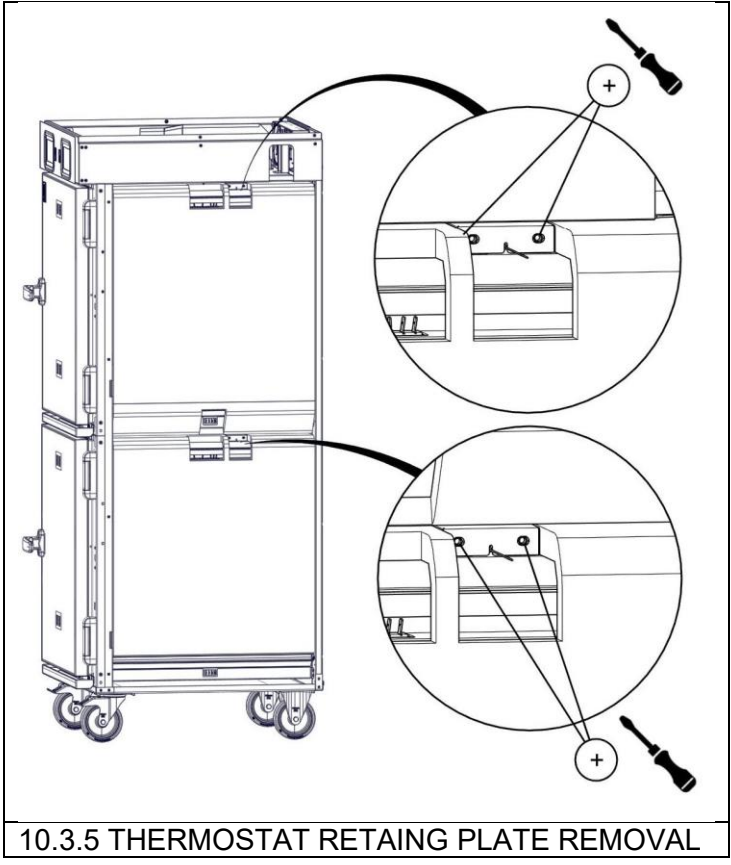

10.3.5 THERMOSTAT RETAINING PLATE REMOVAL

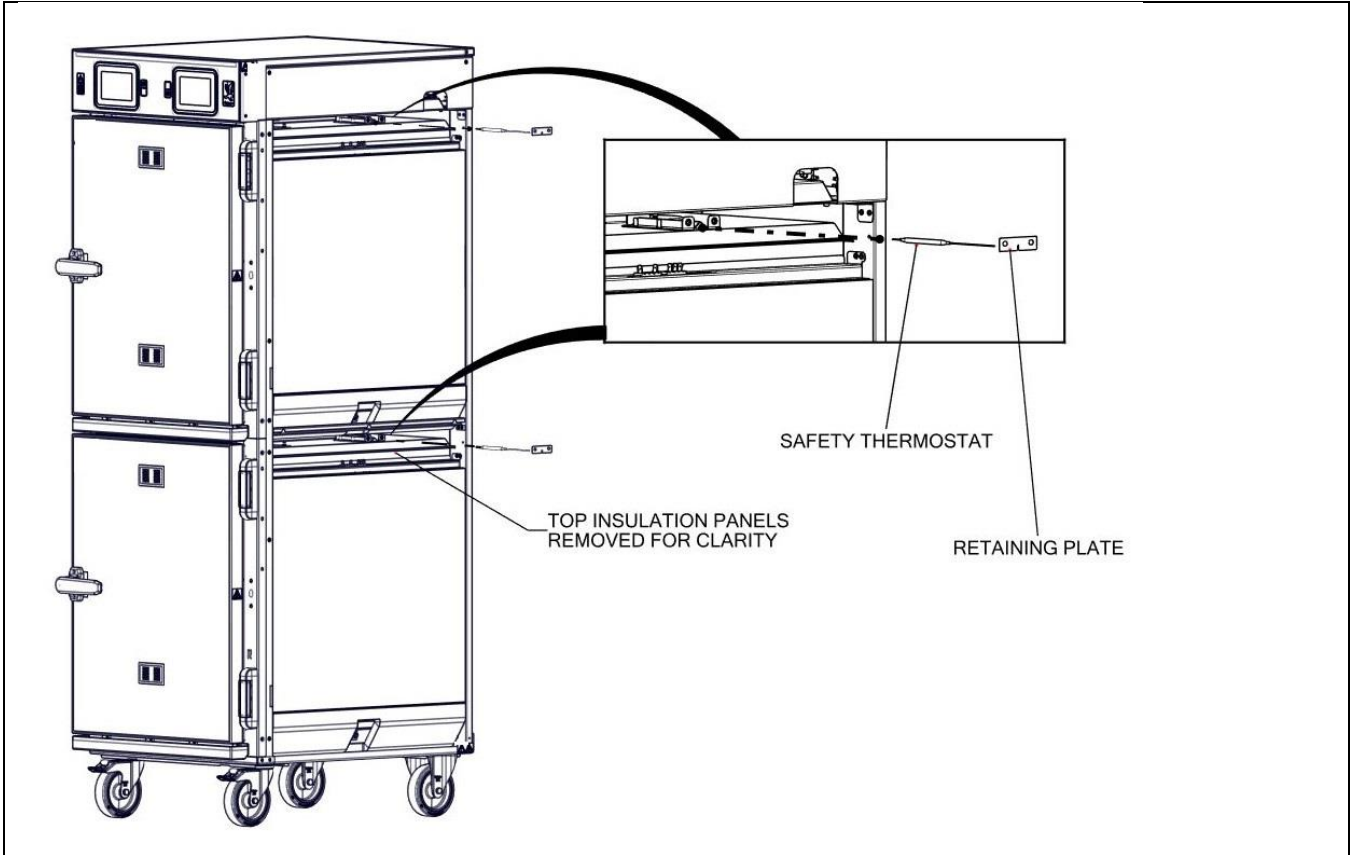

10.3.6 THERMOSTAT REMOVAL

10.4 DRIP TROUGH GASKET REPLACEMENT

- 10.4.1** Remove the drip trough by loosening the thumb screws (turn them counterclockwise).
- 10.4.2** Push the trough towards the left-hand side to allow it to drop down, remove the trough from the appliance.
- 10.4.3** To remove or replace the gasket, fully remove the thumbscrews.
- 10.4.4** Peel off the old gasket from the frame. Make sure all adhesive and tape residues are completely removed.
- 10.4.5** Clean the frame thoroughly to remove all debris and ensure a smooth surface for the new gasket.
- 10.4.6** The gasket has double-sided tape attached. Peel back a small portion of the tape on one side, align the gasket carefully with the frame, then gradually peel off the remaining backing while pressing the gasket firmly onto the frame to ensure full adhesion.
- 10.4.7** Reattach the drip trough to the appliance by reversing steps 10.4.2 and 10.4.1 (slide it into position, then tighten the thumb screws clockwise).
- 10.4.8** Verify that the trough is securely in place and the gasket is properly seated without gaps.

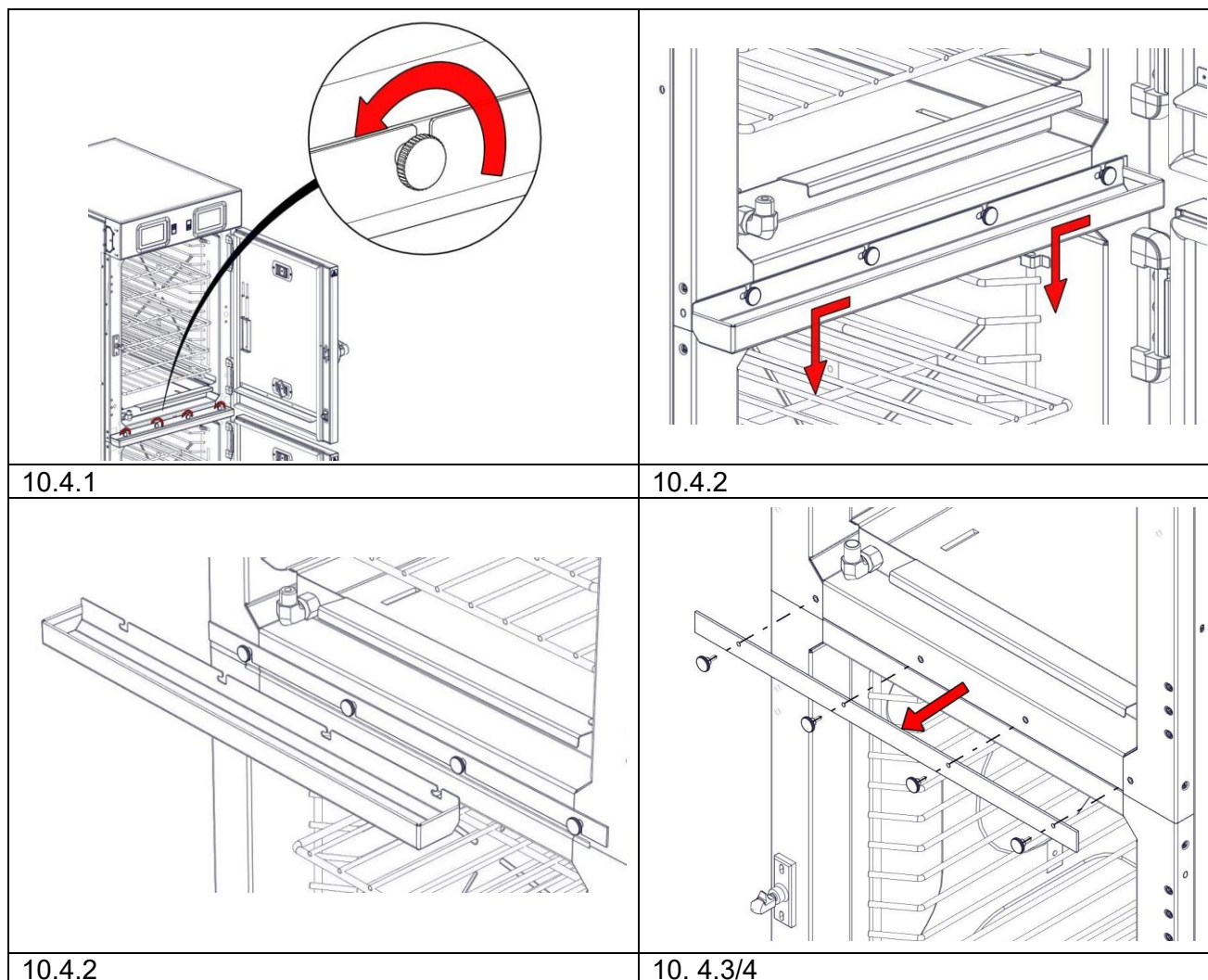

10.5 COVER REMOVAL / REPLACEMENT



BEFORE ATTEMPTING ANY MAINTENANCE, ISOLATE THE APPLIANCE AT THE MAINS SWITCH AND TAKE STEPS TO ENSURE THAT IT IS NOT INADVERTENTLY SWITCHED ON.



ENSURE TO USE INSULATED/NON-CONDUCTIVE STEPLADDER TO PROVIDE PROTECTION AGAINST ELECTROCUTION.

ENSURE TO RECEIVE LADDER SAFETY TRAINING AND DETERMINE THE POTENTIAL RISK BEFORE USE THE LADDER.

10.5.1 Remove the cover by undoing the top and three fixings on either side of the appliance.

10.5.2 Slide the panel forward to remove it from the appliance.

10.5.3 To replace, slide the cover into position and secure it by tightening the top screw and the three fixings on each side.

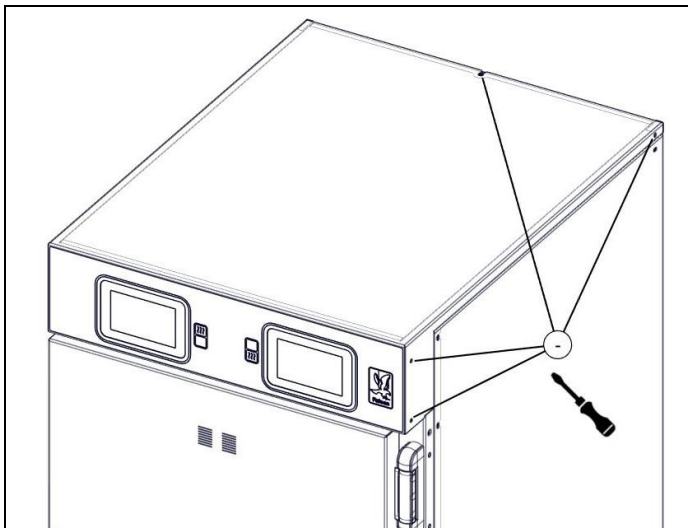

10.5.1

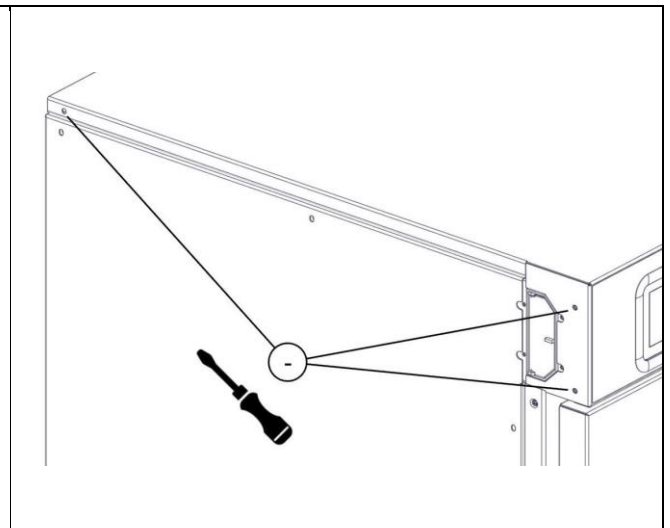

10.5.1

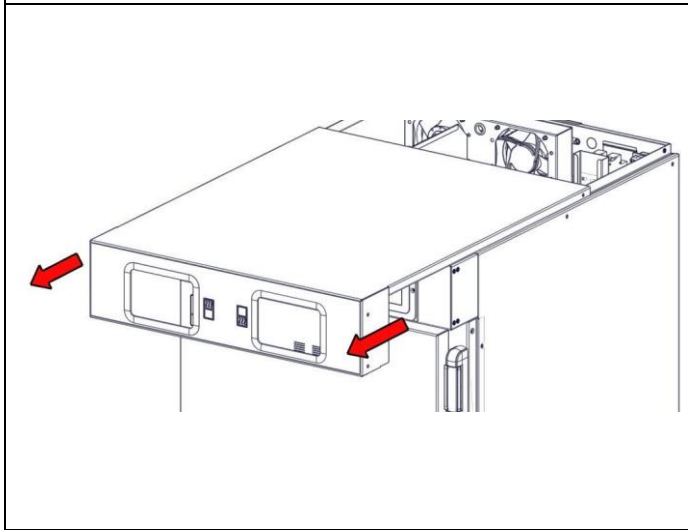

10.5.2

10.6 TOUCHSCREEN REPLACEMENT



BEFORE ATTEMPTING ANY MAINTENANCE, ISOLATE THE APPLIANCE AT THE MAINS SWITCH AND TAKE STEPS TO ENSURE THAT IT IS NOT INADVERTENTLY SWITCHED ON.

10.6.1 Remove the cover as described in section 10.5.

10.6.2 Disconnect the relevant cable connectors from the touchscreen.

10.6.3 Remove fixings from the touchscreen and then carefully ease the touchscreen and its gasket outward from the control box.

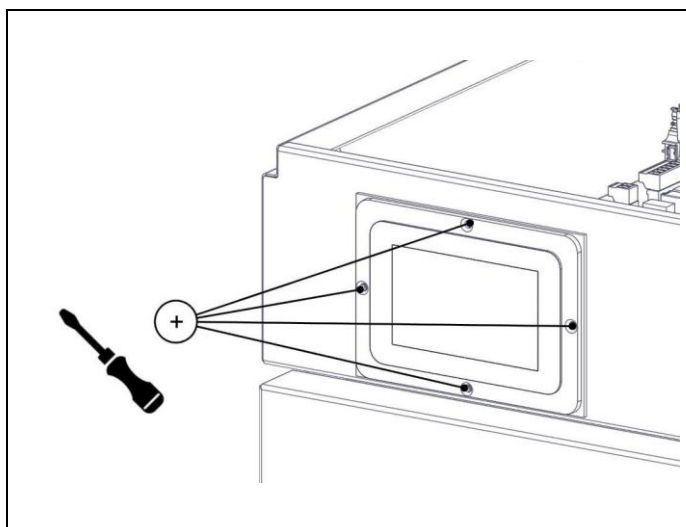

10.6.3

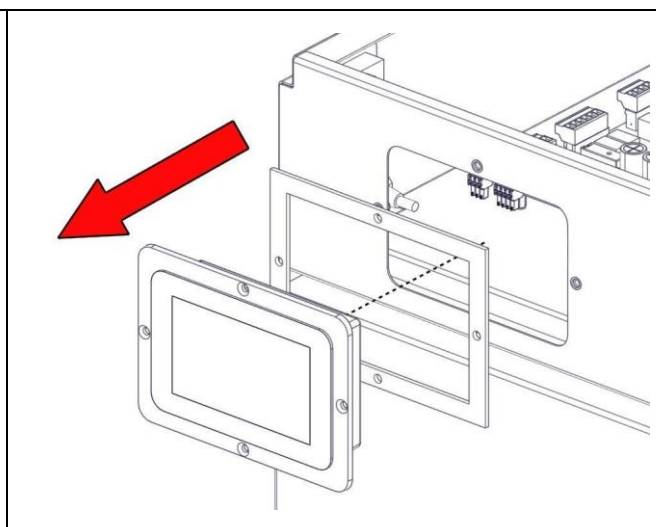

10.6.3

10.6.4 Refit the touchscreen in reverse order, securing all fixings. Do not overtighten the fixings to avoid damaging the touchscreen or gasket.

10.6.5 Ensure the replacement touchscreen is fitted with a gasket as shown above.

10.6.6 When re-fitting, ensure all electrical connections are restored as detailed in the wiring diagram.

10.6.7 Reattach the cover following the procedure in section 10.5 and verify that the touchscreen is securely mounted and fully operational.

10.7 I/O POWERBOARD REPLACEMENT



BEFORE ATTEMPTING ANY MAINTENANCE, ISOLATE THE APPLIANCE AT THE MAINS SWITCH AND TAKE STEPS TO ENSURE THAT IT IS NOT INADVERTENTLY SWITCHED ON.



I/O BOARD IS SUPPLIED IN A ESD PACKING. WHEN REPLACING ENGINEER SHOULD TOUCH THE CHASSIS SURFACE TO DISCHARGE HIMSELF BEFORE REMOVING THE REPLACEMENT BOARD FROM THE PACKING

10.7.1 Remove the cover as described in section 10.5.

10.7.2 Unplug all connectors from the power board.

10.7.3 Using a 5.5mm Socket un-do six plastic nuts on the I/O power board.

10.7.4 Remove I/O power board

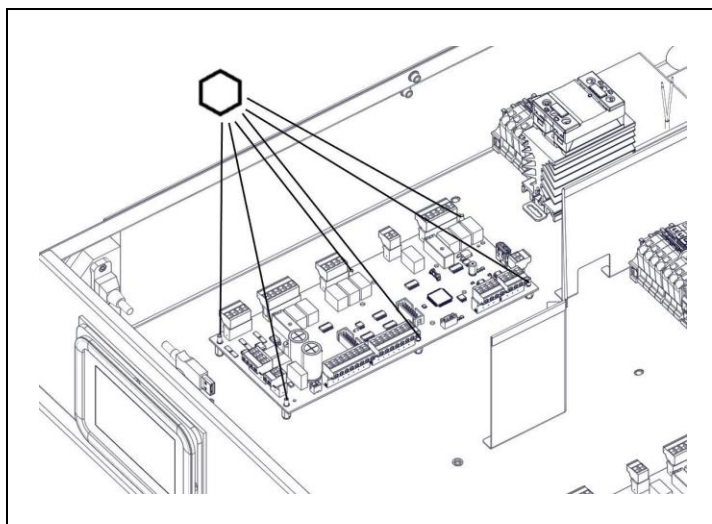

10.7.3

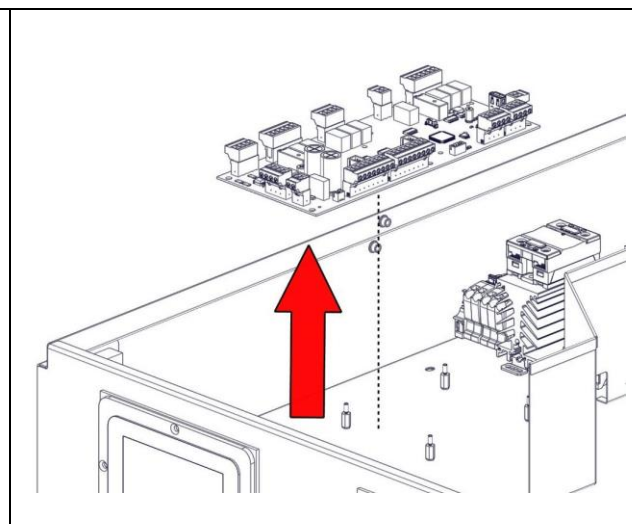

10.7.4

10.7.5 Refit the board in reverse order, securing all plastic nuts are securely fastened.

10.7.6 When re-fitting, ensure all cable connections are restored as detailed in the wiring diagram.

10.8 SIDE PANEL REMOVAL



BEFORE ATTEMPTING ANY MAINTENANCE, ISOLATE THE APPLIANCE AT THE MAINS SWITCH AND TAKE STEPS TO ENSURE THAT IT IS NOT INADVERTENTLY SWITCHED ON.

10.8.1 Remove the three fixings on the base of the appliance.

10.8.2 Remove the fixings on the rear of the appliance.

10.8.3 Remove the fixings on the side of the appliance.

10.8.4 Remove the side panel from the appliance.

10.8.5 Replace the side panel by refitting it in reverse order, ensuring all fixings are securely tightened.

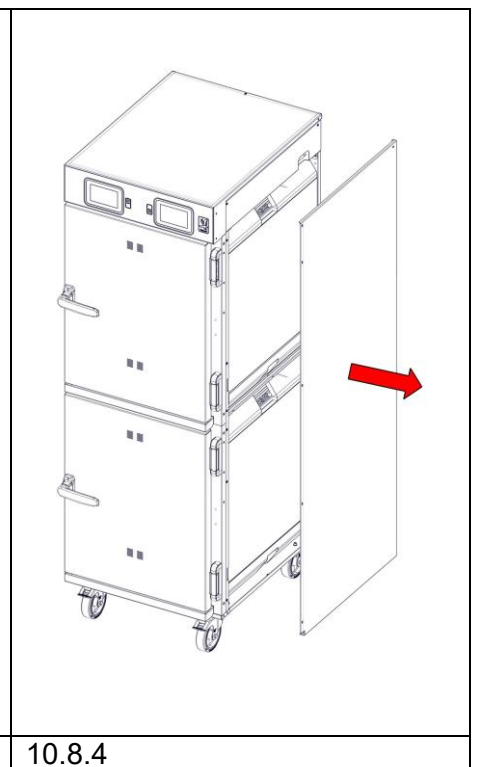
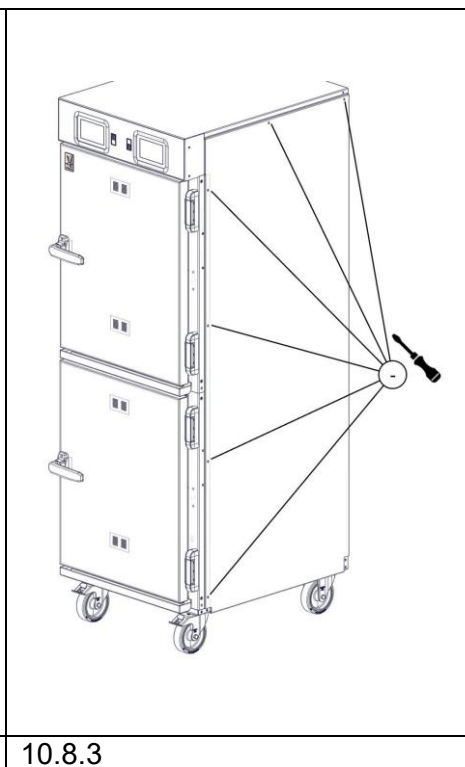
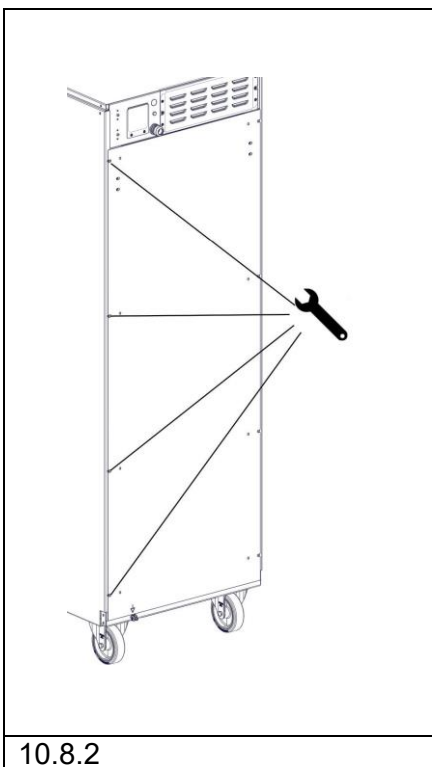
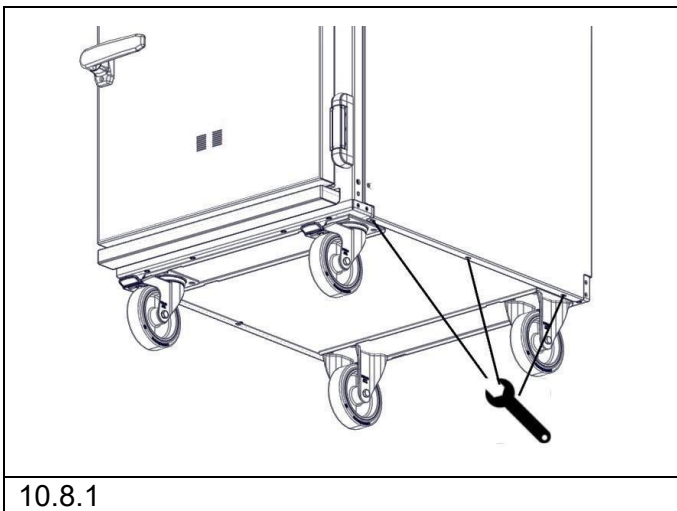

10.9 SIDE ELEMENT REMOVAL / REPLACEMENT



BEFORE ATTEMPTING ANY MAINTENANCE, ISOLATE THE APPLIANCE AT THE MAINS SWITCH AND TAKE STEPS TO ENSURE THAT IT IS NOT INADVERTENTLY SWITCHED ON.

10.9.1 Remove sides as described in section 10.8.

10.9.2 Disconnect the wiring from the side element terminals. Remove and separate any wiring from the insulation wrap.

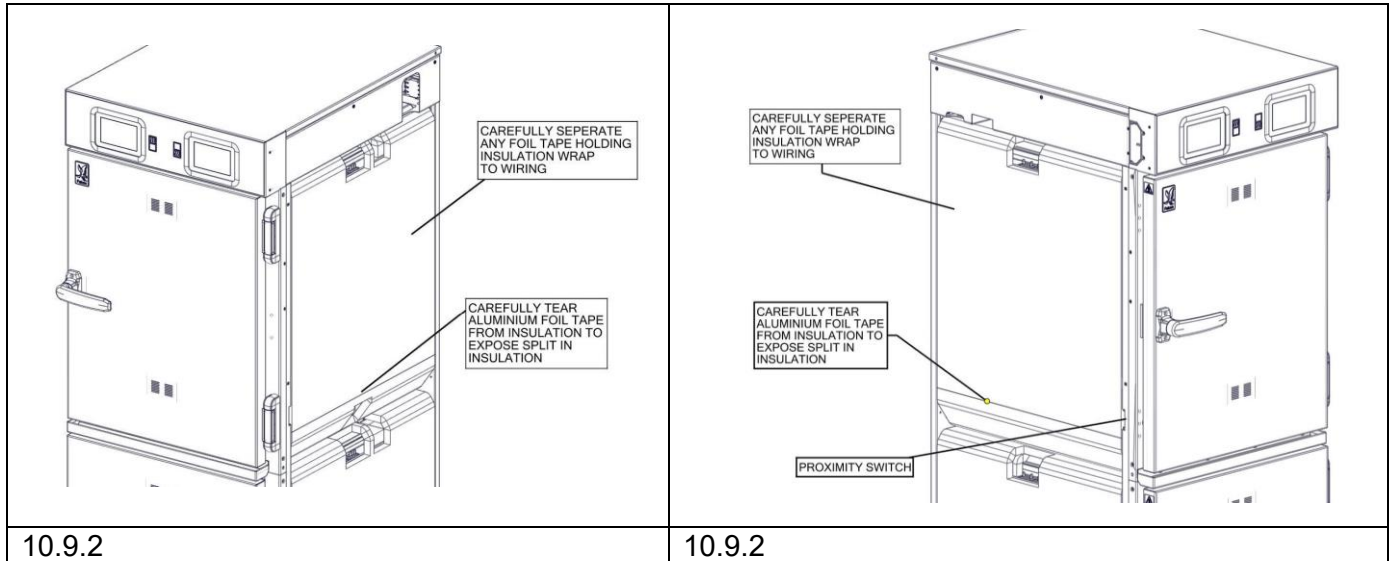

10.9.3 Remove the aluminium foil tape that joins the insulated corners to the wrap.

10.9.4 Remove the insulation from the oven side element.

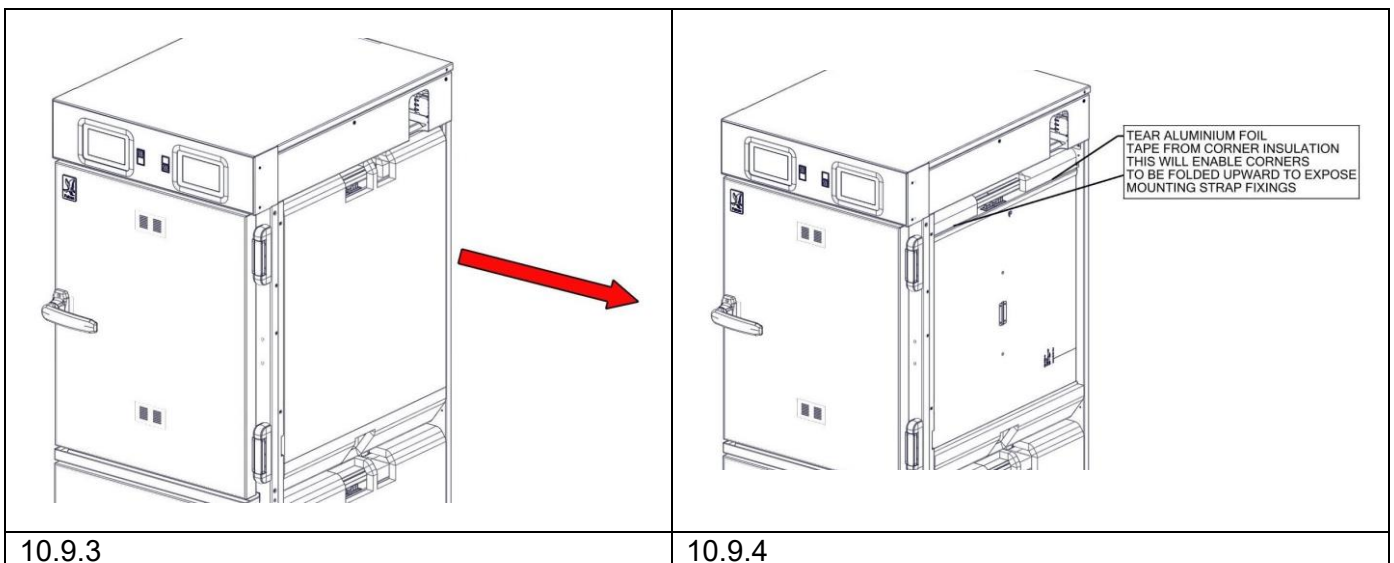

10.9.5 To open the Jubilee band, turn the worm drive screw counterclockwise using a flathead screwdriver or suitable socket. Continue loosening until the band expands, then slide the clip off once it is loose enough.

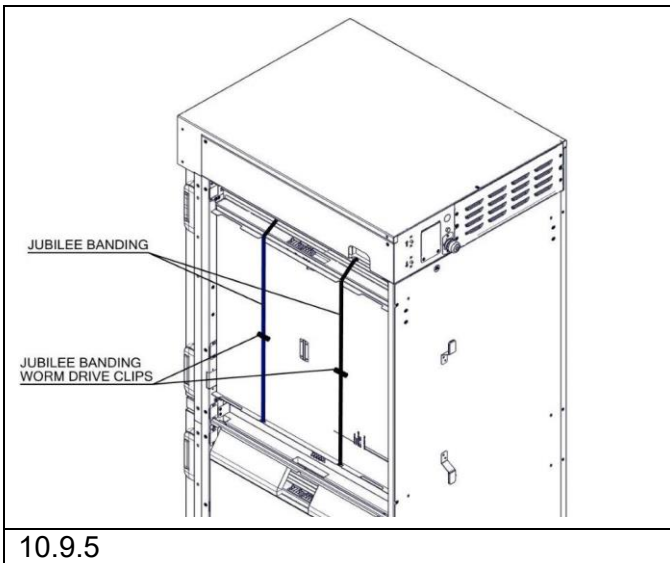

10.9.6 Remove screws from element mounting straps

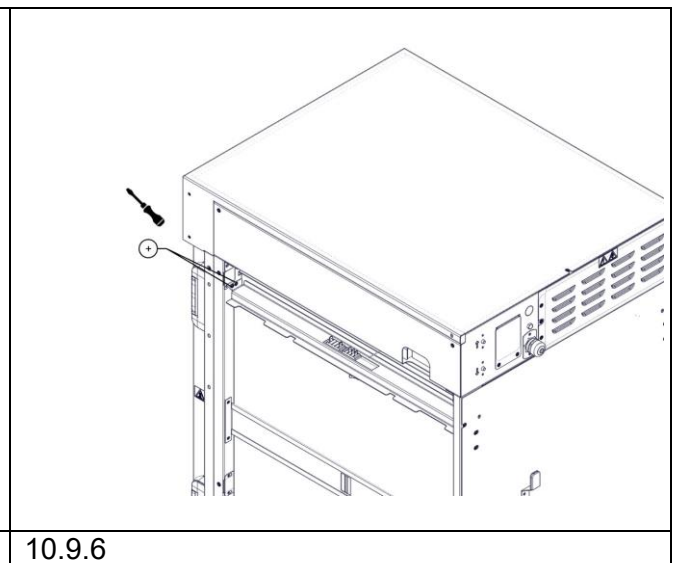
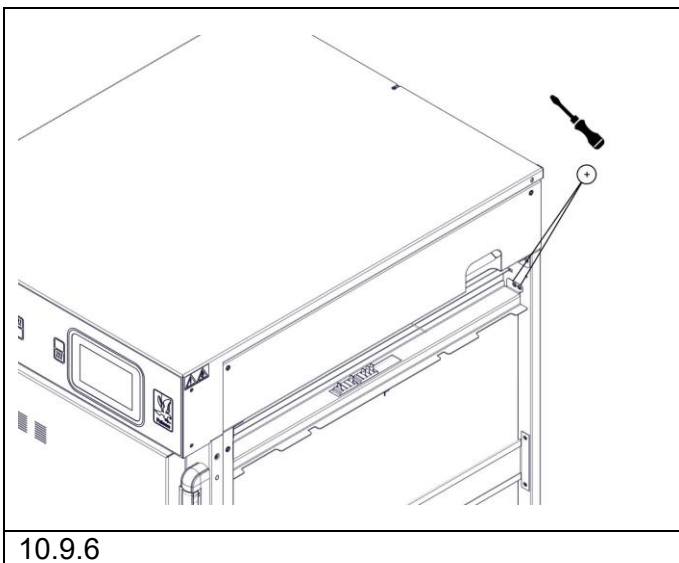

10.9.7 Lift the element mounting strap and remove it from the appliance.

10.9.8 Remove element from the appliance.

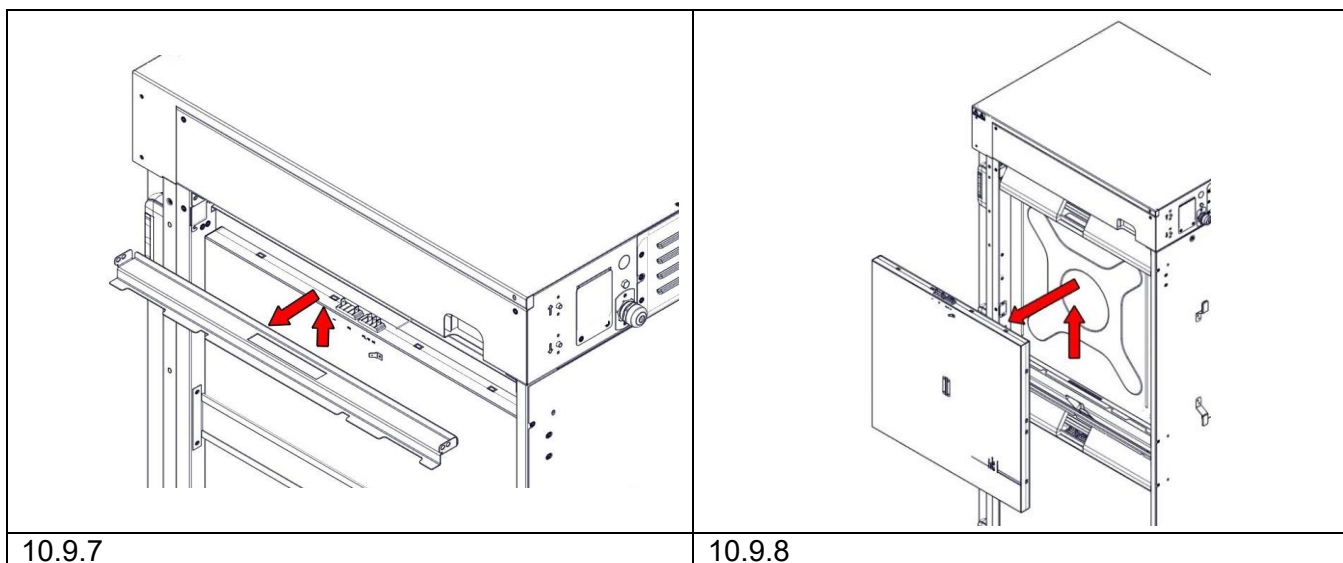

10.9.9 Replace the elements in reverse order, ensuring each element is properly seated in the bottom strap.

10.9.10 Replace the Jubilee band by following the removal steps in reverse order and tighten it securely.

10.9.11 When re-fitting, ensure all electrical connections are restored as detailed in the wiring diagram.

10.10 BASE ELEMENT REMOVAL / REPLACEMENT



BEFORE ATTEMPTING ANY MAINTENANCE, ISOLATE THE APPLIANCE AT THE MAINS SWITCH AND TAKE STEPS TO ENSURE THAT IT IS NOT INADVERTENTLY SWITCHED ON.

10.10.1 Remove sides as described in section 10.8.

10.10.2 Disconnect the wiring from the base element terminals and remove the foil tape that joins the insulated corners to the wrap.

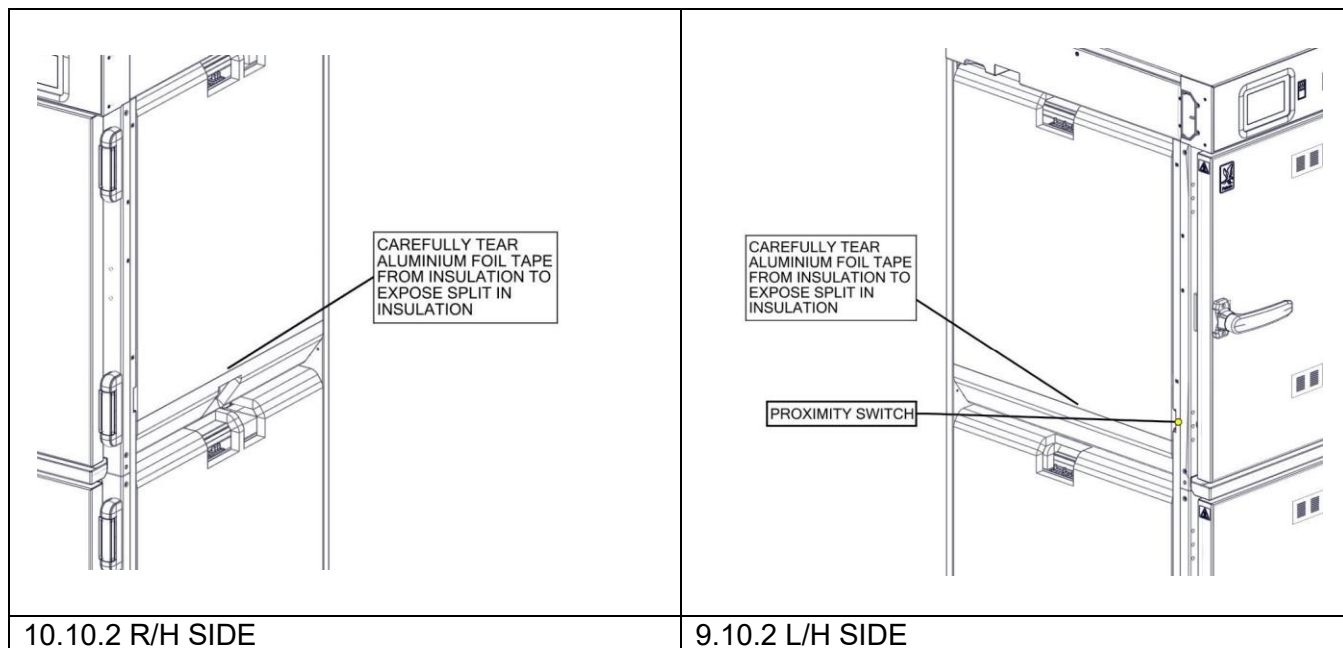

10.10.3 Move the base insulation flap down and remove insulation from the appliance.

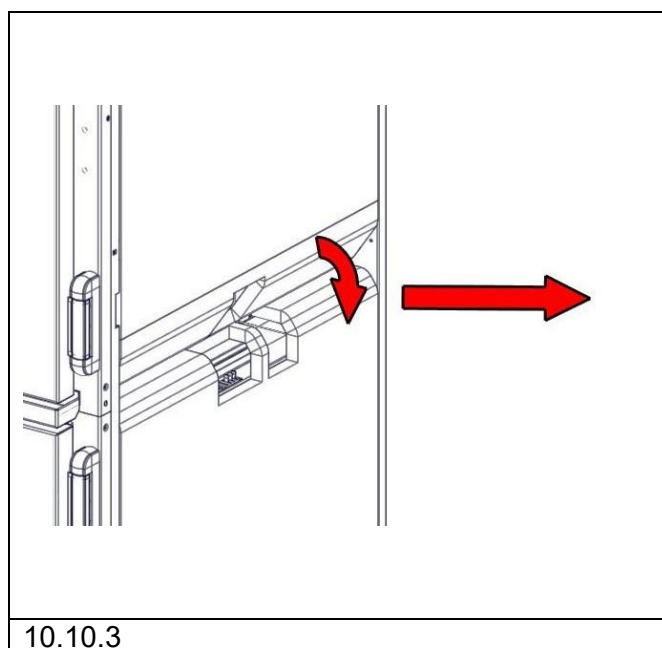

10.10.4 Remove the aluminum foil tape that joins the insulated corners to the element mounting strap.

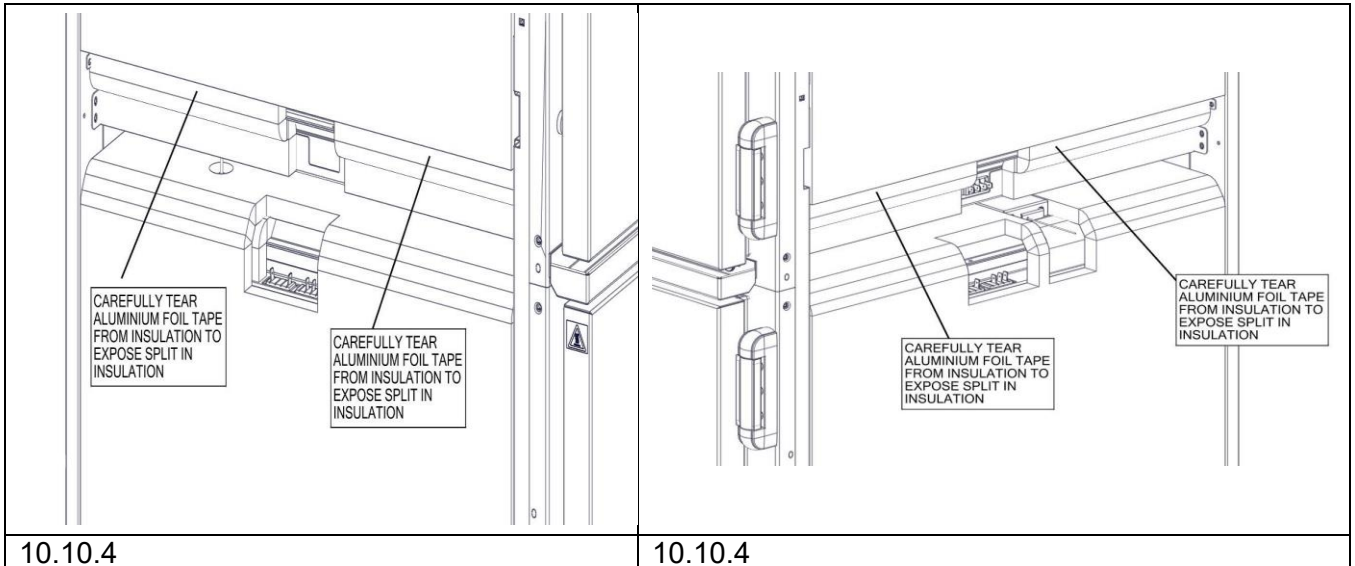

10.10.5 Remove screws from element mounting straps

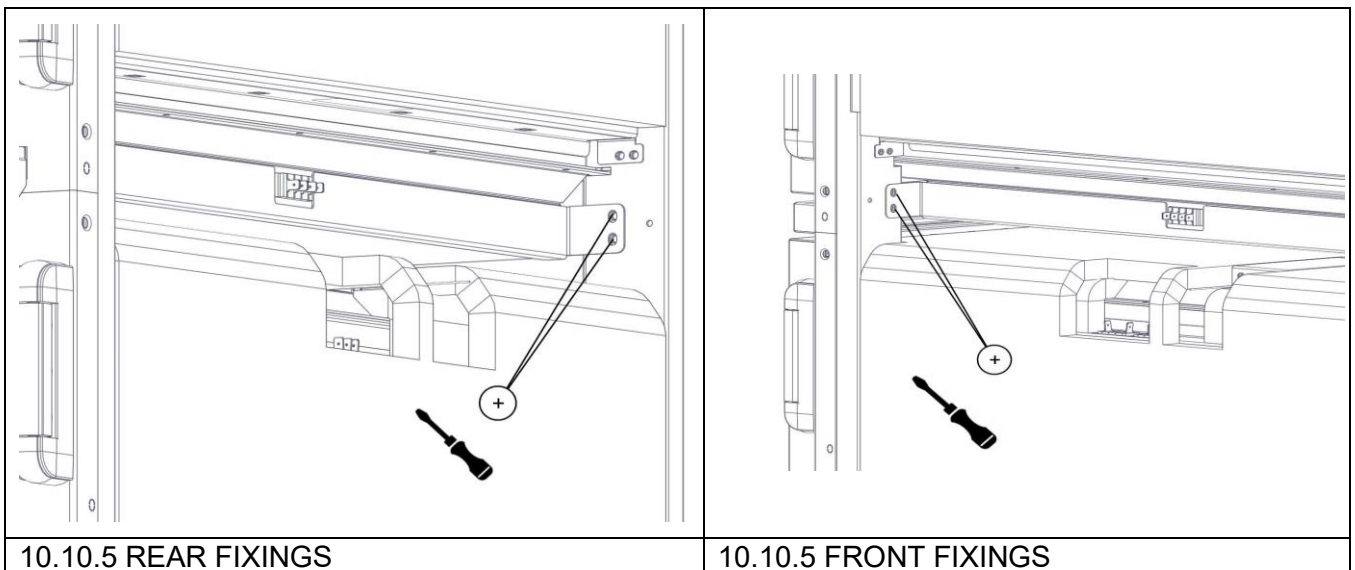

10.10.6 Lift the element mounting strap.

10.10.7 Remove the element from the appliance.

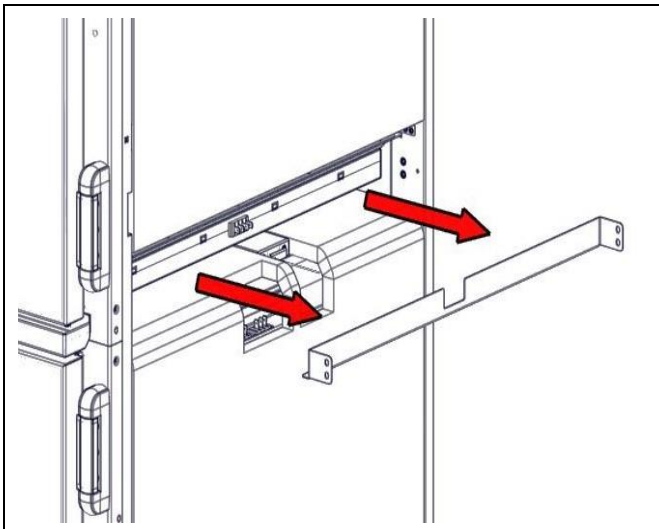

10.10.6

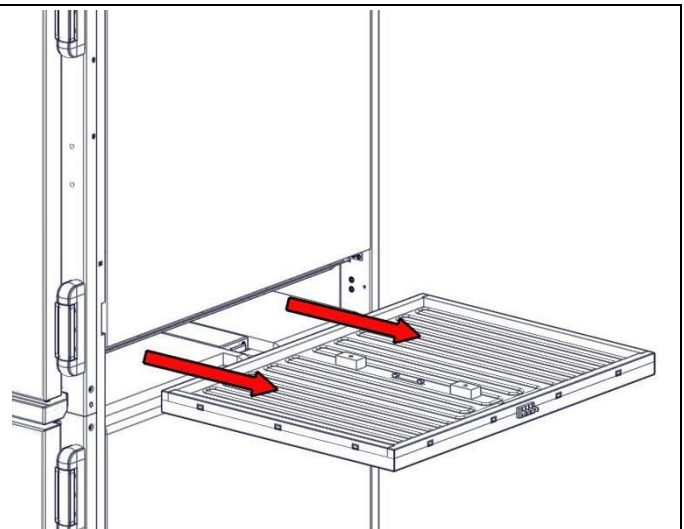

10.10.7

10.10.8 Refit the element in reverse order. Ensure the element straps hold the elements firmly against the oven chamber with no gaps and tighten all fixings securely.

10.10.9 When re-fitting, ensure all electrical connections are restored as detailed in the wiring diagram.

10.11 FUSE REPLACEMENT



BEFORE ATTEMPTING ANY MAINTENANCE, ISOLATE THE APPLIANCE AT THE MAINS SWITCH AND TAKE STEPS TO ENSURE THAT IT IS NOT INADVERTENTLY SWITCHED ON.

10.11.1 Remove/replace cover as described in section 10.5

10.11.2 Open the fuse holder, replace the fuse, and return the fuse holder to its original position.

Note: Use only **0.5A T-type** fuse

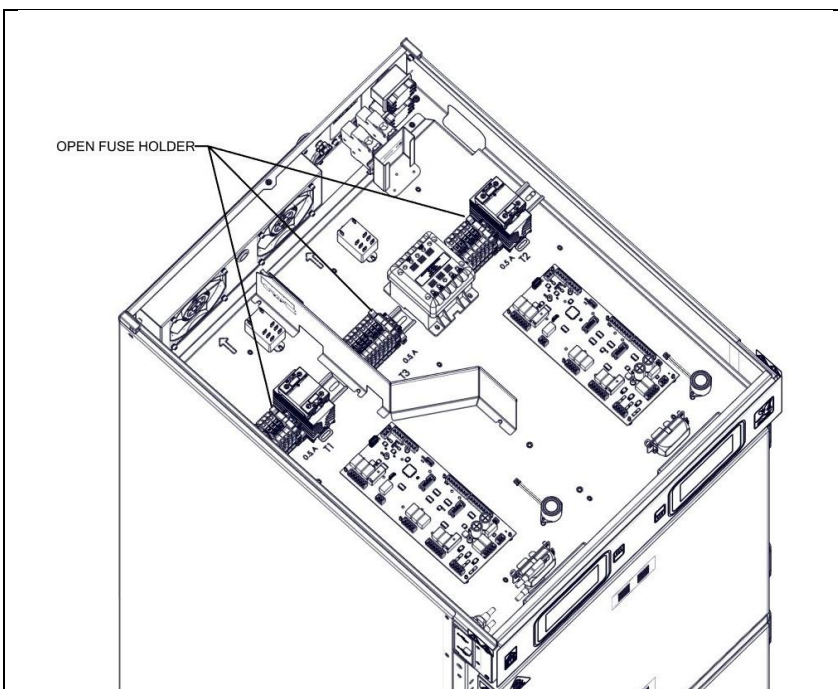

10.11.2

10.12 RELAY REMOVAL / REPLACEMENT



BEFORE ATTEMPTING ANY MAINTENANCE, ISOLATE THE APPLIANCE AT THE MAINS SWITCH AND TAKE STEPS TO ENSURE THAT IT IS NOT INADVERTENTLY SWITCHED ON.

10.12.1 Remove cover as described in section 10.5.

10.12.2 Unplug wires from the relay and remove both screws to release the relay from the panel.

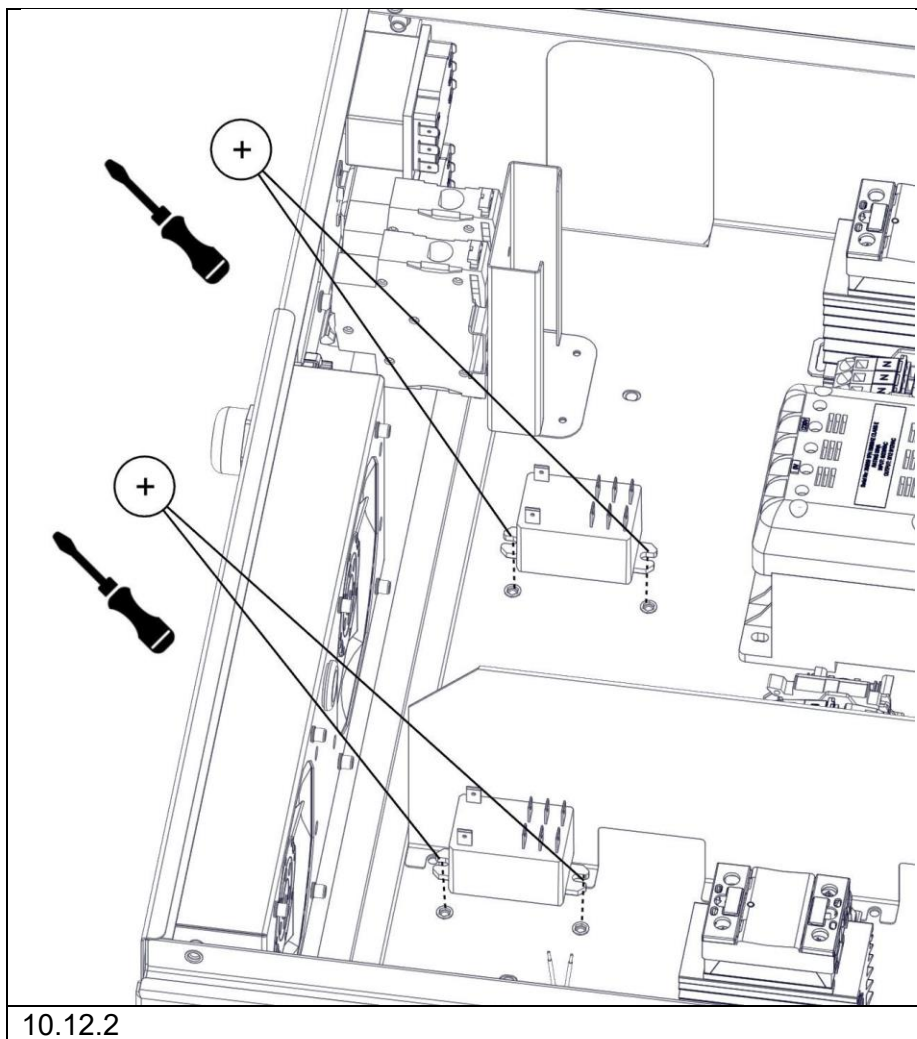

10.12.3 Refit the relay in reverse order.

10.12.4 When re-fitting, ensure all electrical connections are as per the wiring diagram.

10.13 SOLID STATE RELAY REPLACEMENT



BEFORE ATTEMPTING ANY MAINTENANCE, ISOLATE THE APPLIANCE AT THE MAINS SWITCH AND TAKE STEPS TO ENSURE THAT IT IS NOT INADVERTENTLY SWITCHED ON.

10.13.1 Remove cover as describe in section 10.5.

10.13.2 Flip the relay covers to the open position, unscrew the terminal screws to release the wires, and then unscrew the relay from the heatsink to release the solid-state relay body.

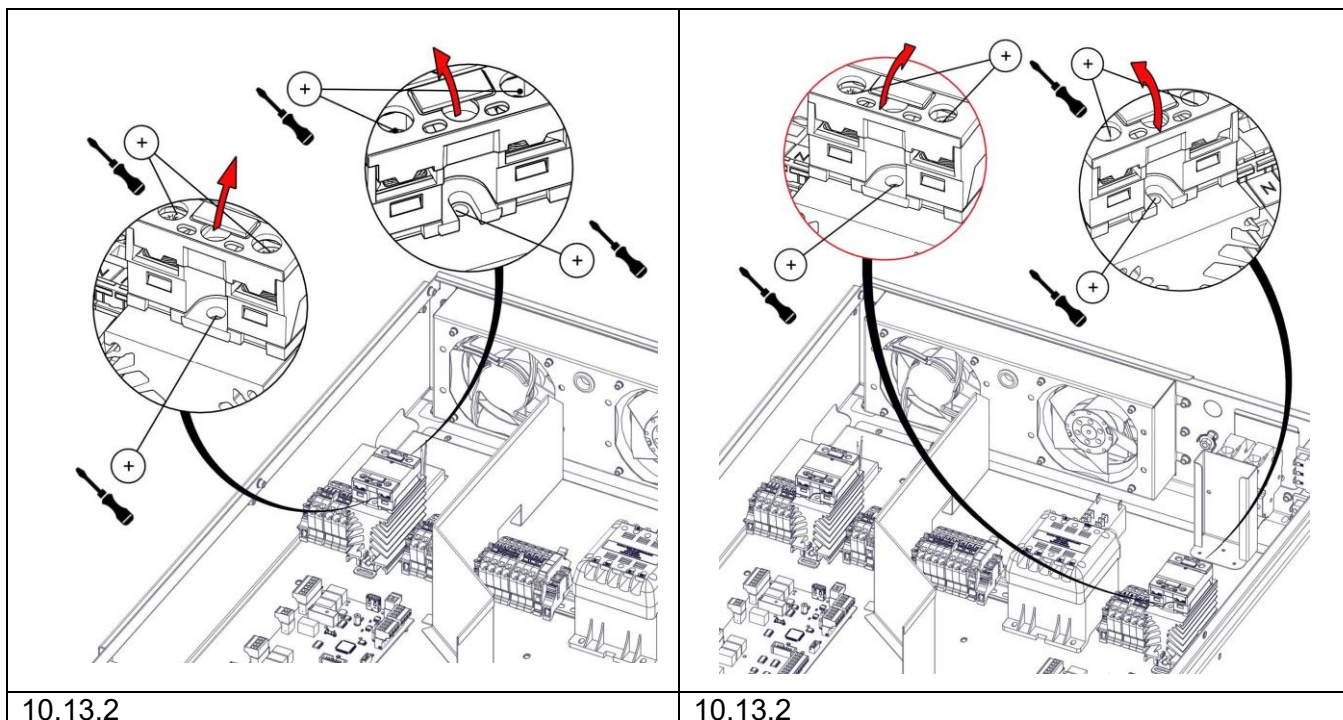

10.13.3 Refit the relay in reverse order.

10.13.4 Ensure heat transfer compound (RS components 554-311) is applied to the joint between the relay and heatsink. Follow manufacturers application instructions.

10.13.5 When re-fitting, ensure all electrical connections are as per the wiring diagram.

10.14 COOLING FAN REPLACEMENT



BEFORE ATTEMPTING ANY MAINTENANCE, ISOLATE THE APPLIANCE AT THE MAINS SWITCH AND TAKE STEPS TO ENSURE THAT IT IS NOT INADVERTENTLY SWITCHED ON.

10.14.1 Remove cover as describe in section 10.5.

10.14.2 Unplug relevant fan wires from the wago connectors inside the control box.

10.14.3 Unscrew the fan cover panel and remove it from the appliance.

10.14.4 Unscrew the fan fixing screws to release the fan from the appliance.

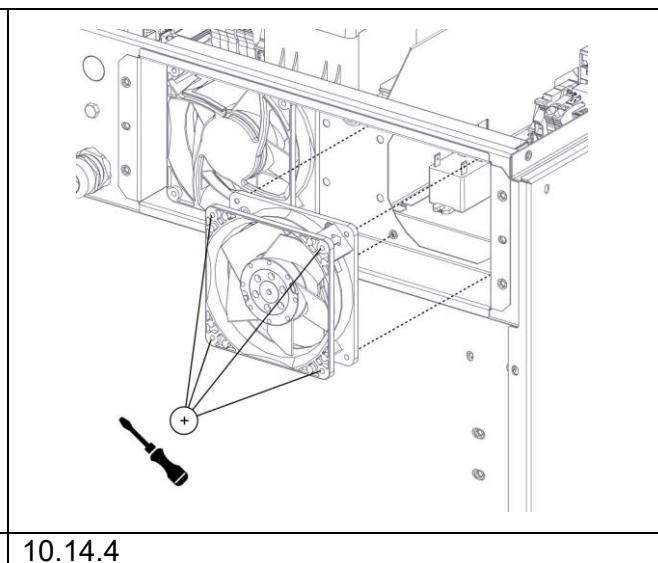
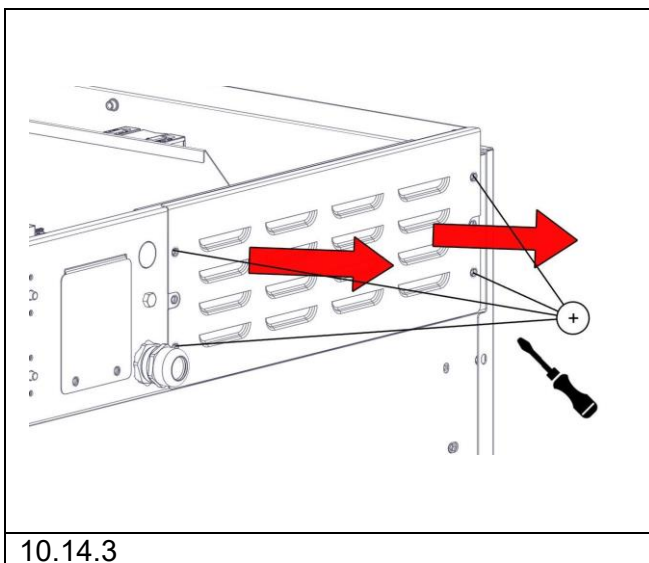

Note: See below the cooling fan's airflow direction for the appliance, ensure fans are oriented to match

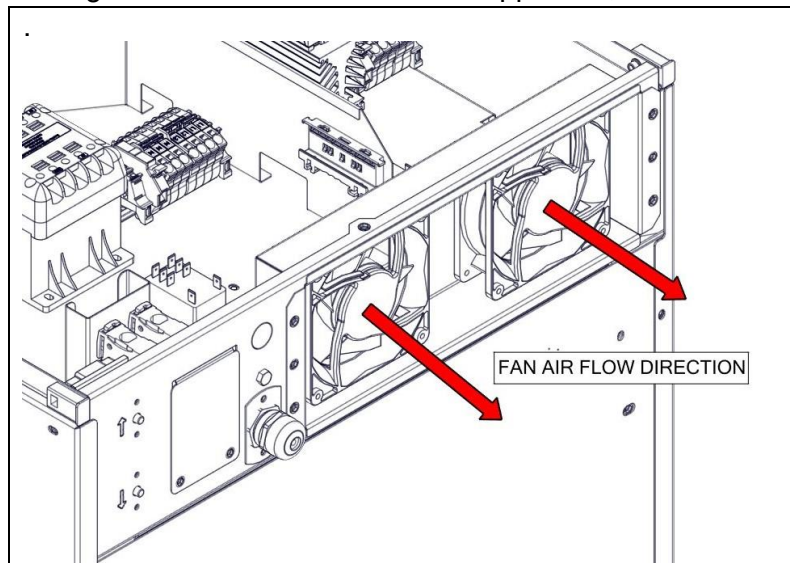

10.14.5 Re-fit in reverse order, ensure all electrical connections are as per the wiring diagram.

10.15 TRANSFORMER REPLACEMENT



BEFORE ATTEMPTING ANY MAINTENANCE, ISOLATE THE APPLIANCE AT THE MAINS SWITCH AND TAKE STEPS TO ENSURE THAT IT IS NOT INADVERTENTLY SWITCHED ON.

10.15.1 Remove cover as describe in section 10.5.

10.15.2 Unplug wires from the transformer and remove four screws to release the transformer from the panel.

10.15.3 Remove transformer from appliance.

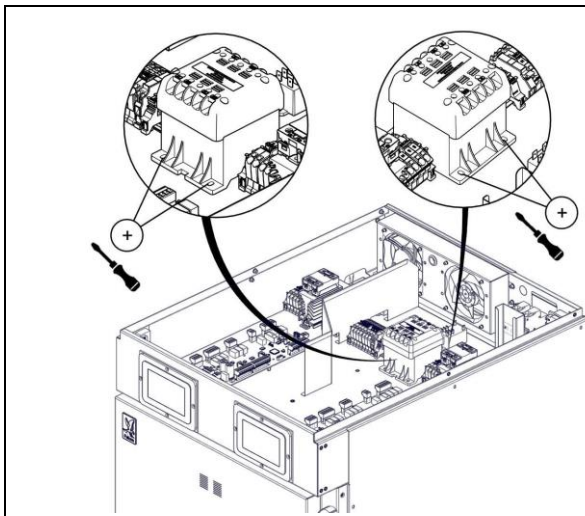

10.15.2

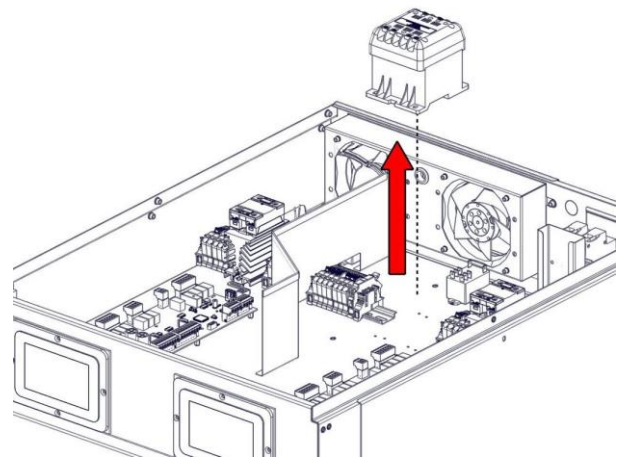

10.15.3

10.15.4 Re-fit in reverse order, ensure all electrical connections are as per the wiring diagram.

10.16 CORE TEMP PROBE PLUG REPLACEMENT



BEFORE ATTEMPTING ANY MAINTENANCE, ISOLATE THE APPLIANCE AT THE MAINS SWITCH AND TAKE STEPS TO ENSURE THAT IT IS NOT INADVERTENTLY SWITCHED ON.

Only valid for CH30-11P / CH15-15P models.

10.16.1 Open door

10.16.2 Unscrew fixings from the chamber to release the probe box.

10.16.3 Unscrew fixings from probe plugs to release from the box

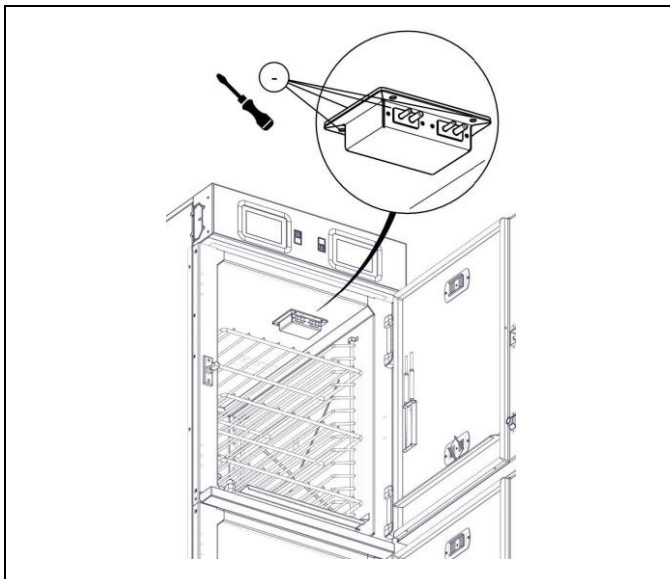

10.16.2

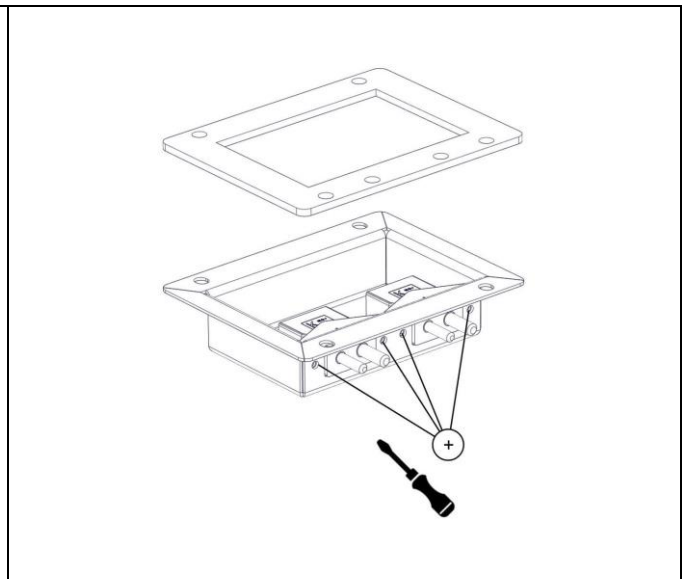

10.16.3

10.16.4 Unscrew the bracket from the plug

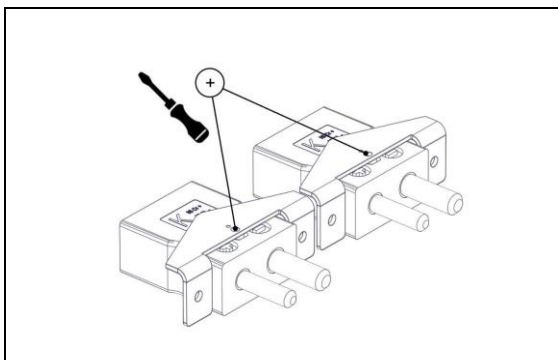

10.16.4

10.16.5 Unscrew two fixings on the plug to expose wire terminals and loosen terminal screws to release cables from the plug.

10.16.6 Re-fit in reverse order, ensure all electrical connections are as per the wiring diagram.

10.17 DOOR SEAL REPLACEMENT

10.17.1 Open the door and pick a corner of the old seal.

10.17.2 Pull the old seal out of the groove all the way around the door.

10.17.3 Clean the groove with a cloth to remove dirt or debris.

10.17.4 Start the new seal at a corner. Make sure it's facing the correct direction.

10.17.5 Push the new seal into the groove with your fingers (no sharp tool), working around the door without stretching it.

10.17.6 Check for gaps and make sure all corners are fully seated.

10.17.7 Close the door to ensure it seals properly.

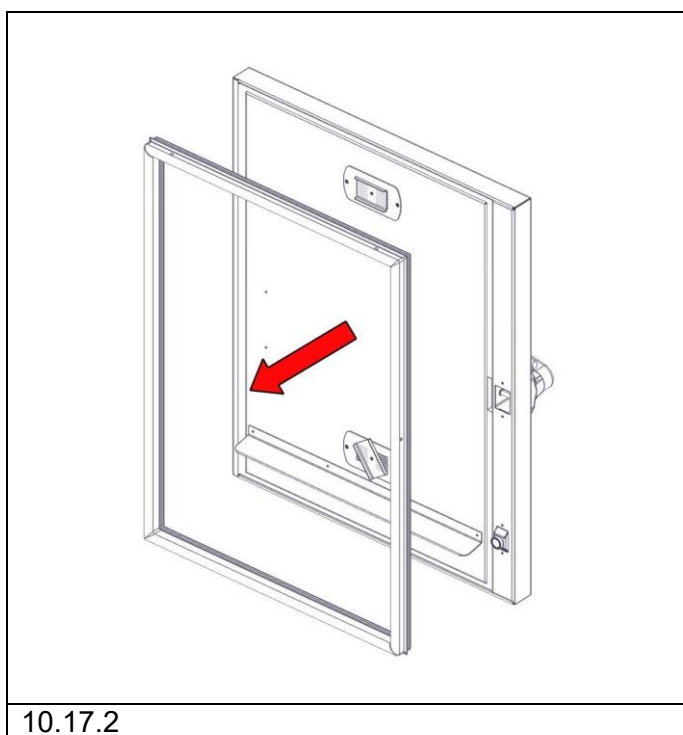

10.17.2

10.18 DOOR PROXIMITY SWITCH REPLACEMENT



BEFORE ATTEMPTING ANY MAINTENANCE, ISOLATE THE APPLIANCE AT THE MAINS SWITCH AND TAKE STEPS TO ENSURE THAT IT IS NOT INADVERTENTLY SWITCHED ON.

10.18.1 Remove the left-hand side panel as describe in 10.8

10.18.2 Disconnect relevant proximity switch pigtail wire from the wago connector.

10.18.3 Pushback enough insulation access proximity switch bracket fixing. Unscrew the bracket fixings to release the bracket from the framework.

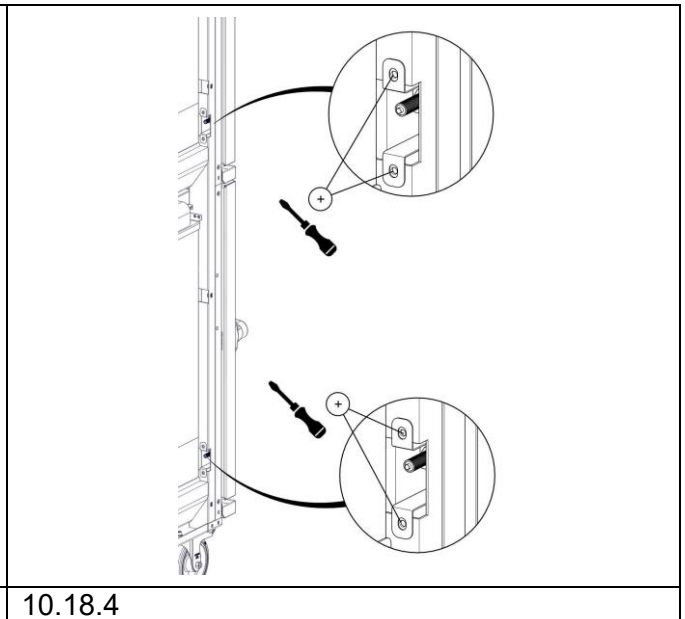
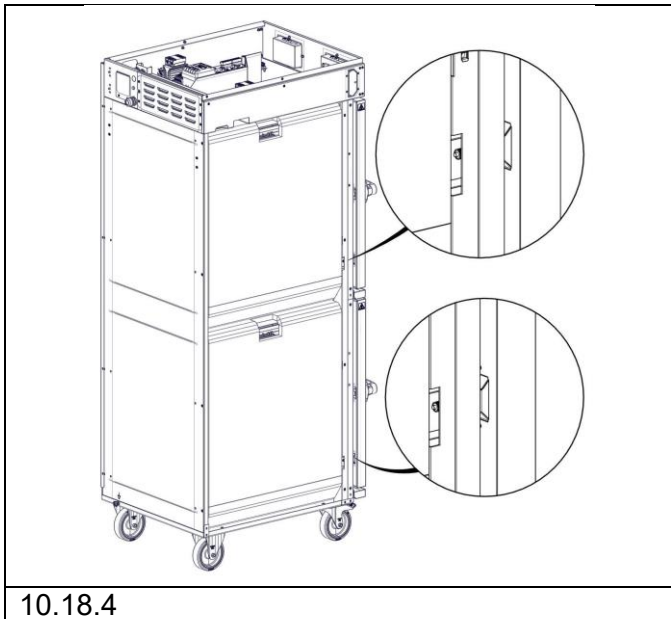

10.18.4 Remove the proximity switch from the bracket.

10.18.5 Re-fit in reverse order, ensure all electrical connections are as per the wiring diagram.

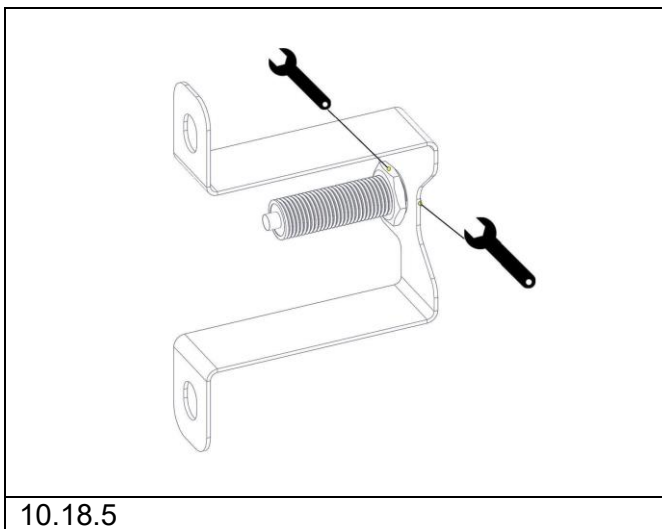

10.19 DOOR REMOVAL / REPLACEMENT

10.19.1 Remove hinge caps from hinges.

10.19.2 Remove screws from the door side to release the door assembly from the appliance.

10.19.3 Re-fit in reverse order.

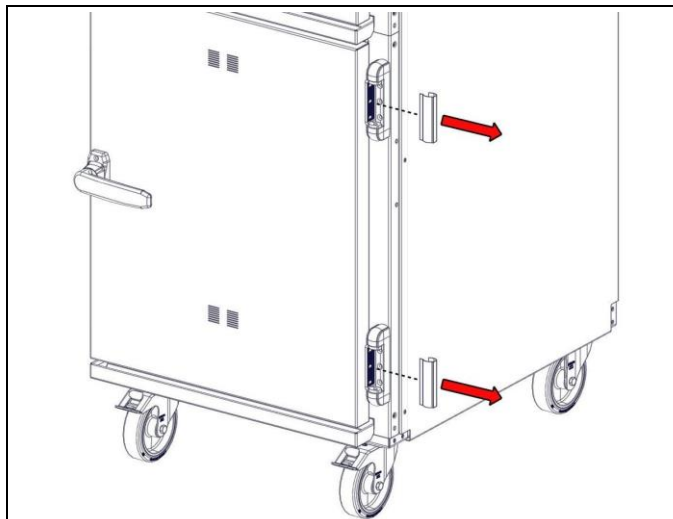

10.19.1

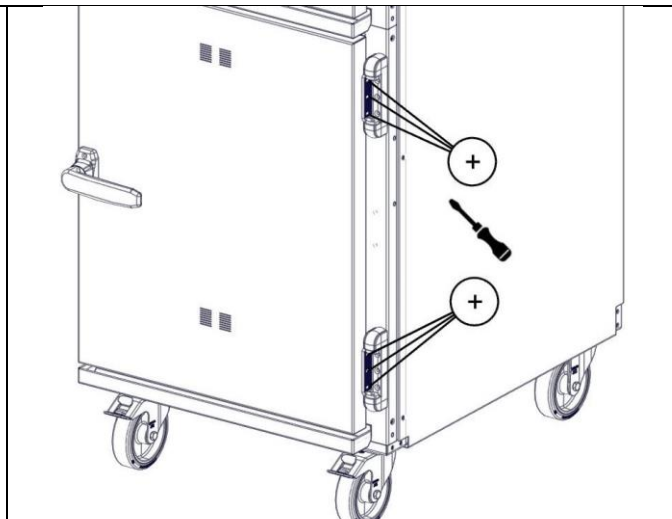

10.19.2

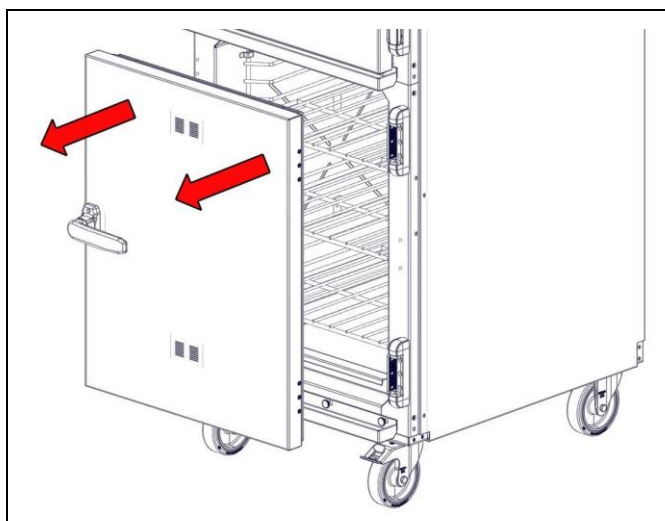

10.19.2

10.20 MCB ACCESS PANEL REMOVAL



BEFORE ATTEMPTING ANY MAINTENANCE, ISOLATE THE APPLIANCE AT THE MAINS SWITCH AND TAKE STEPS TO ENSURE THAT IT IS NOT INADVERTENTLY SWITCHED ON.

10.20.1 Remove screws from the access panel to release from the appliance.

10.20.2 Remove the panel.

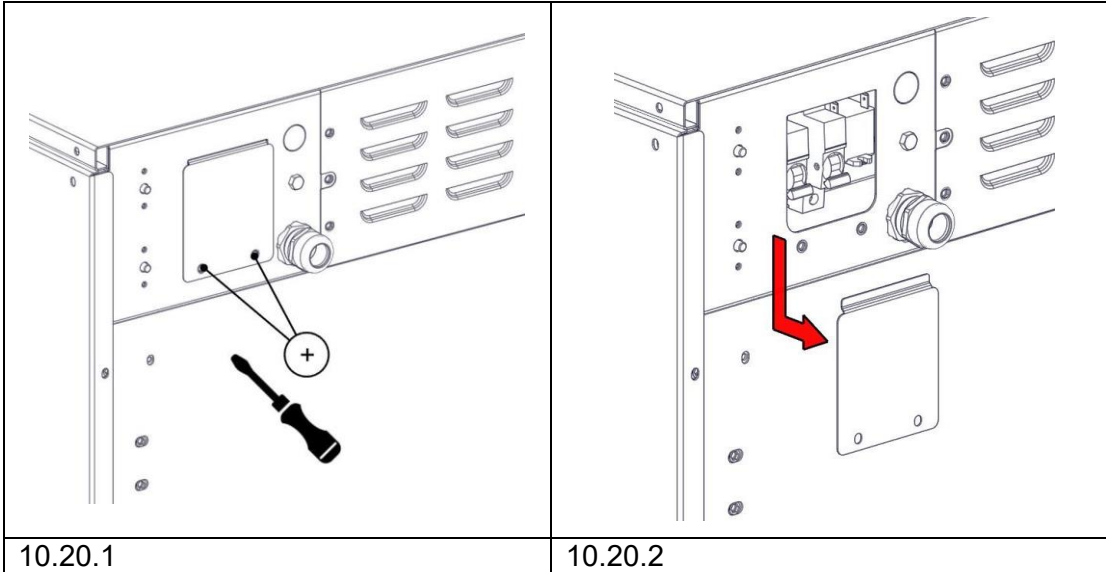

10.21 HOW TO VIEW AND UPDATE FIRMWARE:

VIEW SOFTWARE REVISION:

10.21.1 Switch off the appliance from mains and turn back on.

10.21.2 Once the display turns on, the first screen displays for few second, the first line is about the software application, the highlighted part is the firmware revision.

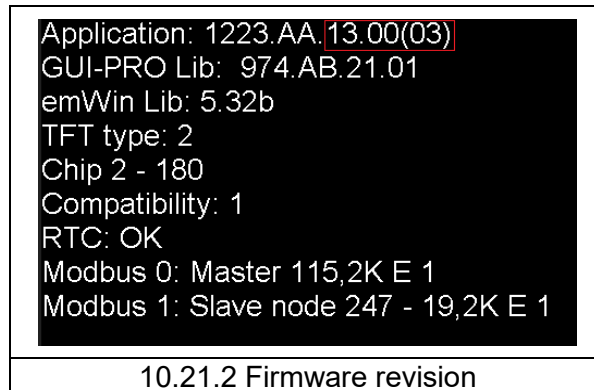

UPDATE THE FIRMWARE (IF REQUIRED):

10.21.3 Download the firmware supplied by Falcon onto an empty USB drive.

10.21.4 Record the firmware revision currently installed on the oven. Refer to section 10.21 for instructions on how to view the current firmware version.

10.21.5 Ensure the appliance is in Standby mode.

10.21.6 Insert the USB key into the designated USB port. The top port is for the upper oven, and the bottom port is for the lower oven.

The program file does not exist

10.21.7 The controller will begin copying the program files. Once all files are copied, it will prompt

10.21.8 After a few seconds, the controller will automatically restart.

10.21.9 When the controller returns to the Standby screen after restarting, re-insert the USB key with the same files.

10.21.10 The controller will automatically create a log file, erase old BMP, GIF, or CSV files, and copy the new files into the controller. It may display a “mandatory files missing” message, this can be safely ignored.

10.21.11 When prompted, remove the USB key. After removal, the screen will automatically reboot again.

10.21.12 Once the screen restarts, the new firmware will be active.

Note: Do not turn off the unit during the firmware update process. Only remove the USB key when the controller prompts you to do so.

The program file already exists

Follow the steps in 10.21.10 through 10.21.12.

10.22 CONTROL BOARD (I/O BOARD)

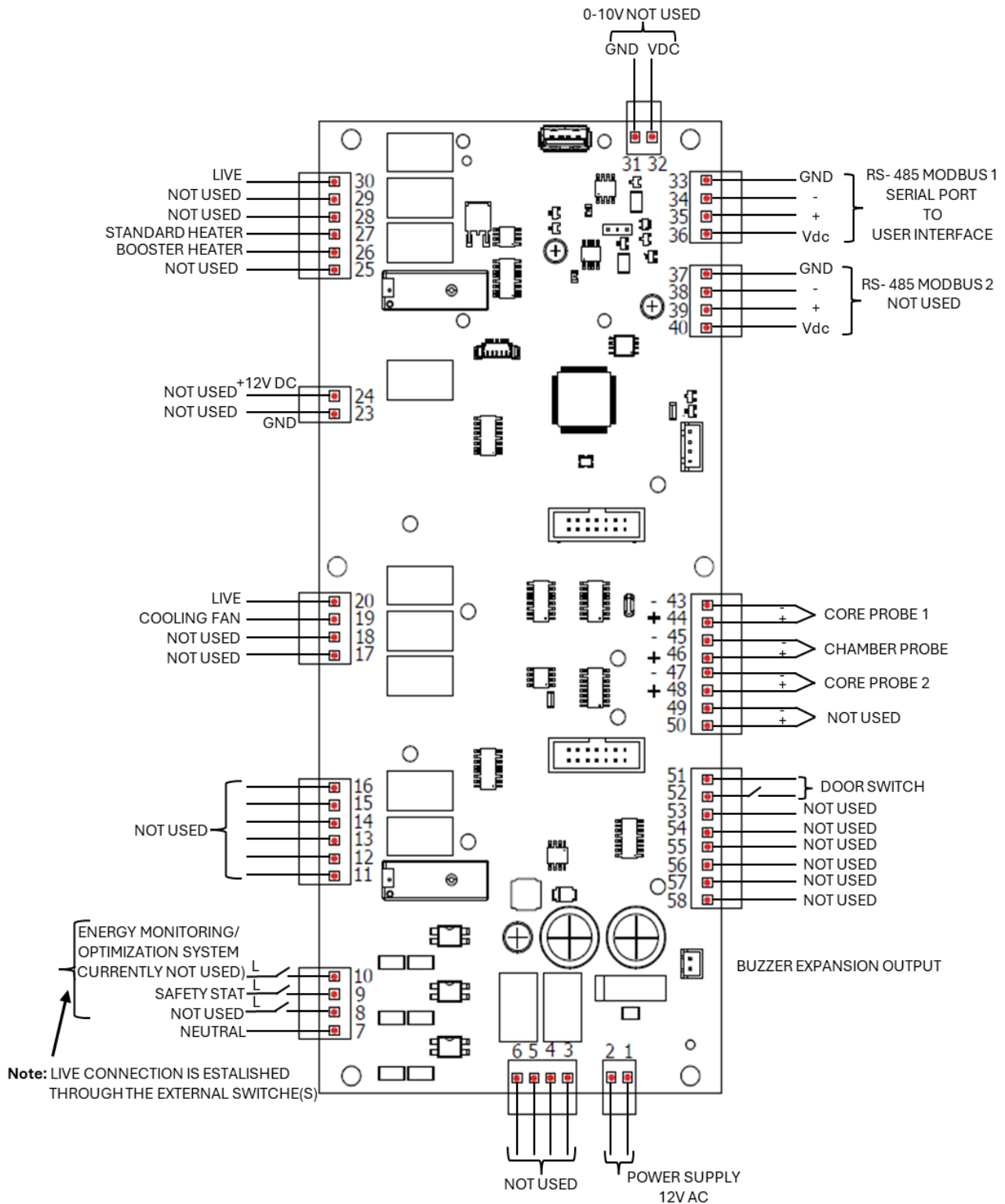



Note: For single ovens, connector pin 18 is used for the second cooling fan. This fan operates only when the control board temperature reaches the defined threshold.

To test the fan, tap the **Spanner** icon on the standby screen, select **Engineering Configuration**, then choose **Output Test**. Enter password **20** and select **Comp Fan**. The fans will run briefly to confirm operation.

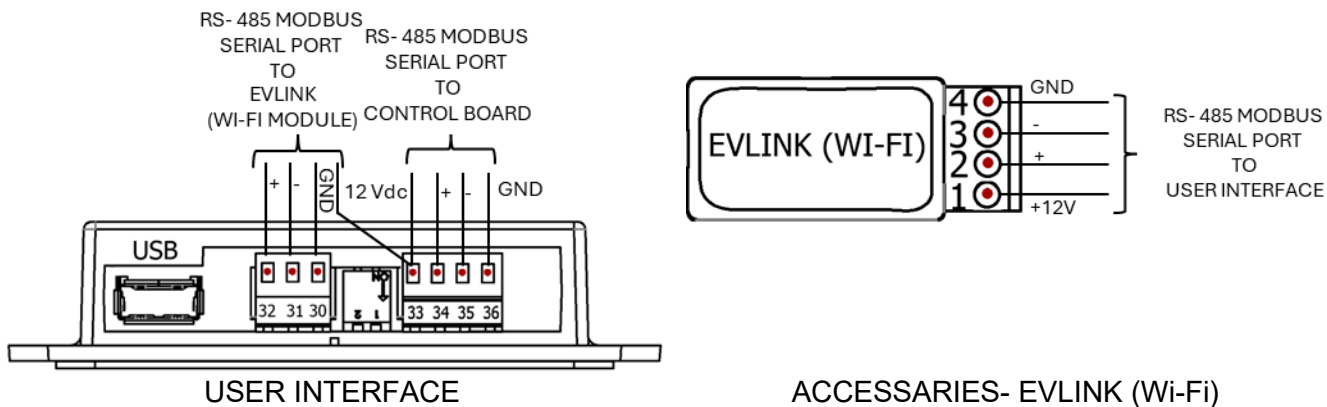

10.23 TOUCH SCREEN (USER INTERFACE) AND EVLINK (WI-FI)





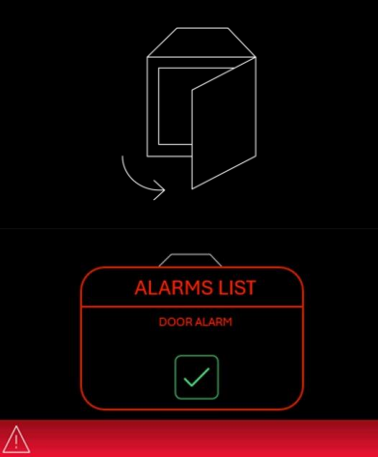

11.0 ALARMS



When an alarm occurs, the buzzer will sound, and an icon  along with a pop-up message will appear on the display to indicate the alarm. To silence the buzzer and return to the normal view, simply tap the  icon. To review the alarm again, simply touch the icon located in the bottom-left corner.

Below is a list of the device's alarms and their meanings.

ALARM	DESCRIPTION
<p>11.1 OVEN DOOR ALARM</p> 	<p>When the oven door is opened, the controller displays a “DOOR OPEN” symbol. During this period, the heating elements remain on to compensate for heat loss.</p> <p>If the door remains open for more than one minute, the controller activates a “DOOR ALARM” and switches off the heating elements.</p> <p>While this alarm is active, the controller pauses the countdown timer for time-based cooking cycles. The countdown will resume once the door is closed.</p> <p>During cook cycle:</p> <p>If the door open during cook cycle the alarm activates straight away as it is not expected to open the door during cooking, and elements will be run for one minute if the door stay open for heat compensation.</p> <p>If an alarm persists, refer to SECTION 12: FAULT FINDING for troubleshooting guidance.</p>
<p>11.2 POWER FAILURE ALARM</p> 	<p>In the event of a power interruption during a cooking cycle, the controller will display a “POWER FAILURE” alarm upon power restoration, showing the total duration of the outage. The alarm will remain active until acknowledged by the user.</p> <ul style="list-style-type: none"> • If the power outage lasts less than 20 minutes, the oven will automatically resume the cooking cycle once power is restored. • If the power outage lasts more than 20 minutes, the cooking cycle will not resume, and the cycle will remain interrupted. <p>Safety Reminder:</p> <p>In the event of a power failure, always refer to your company’s policy for guidance. Food that has been exposed to unsafe temperatures must be discarded in accordance with local regulations and your organization’s food safety procedures.</p> <p>If you are unsure whether the food is safe, discard it immediately.</p> 

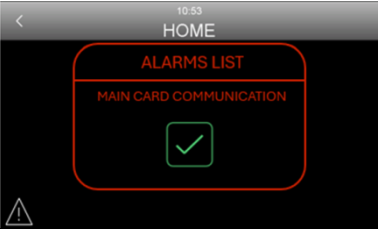
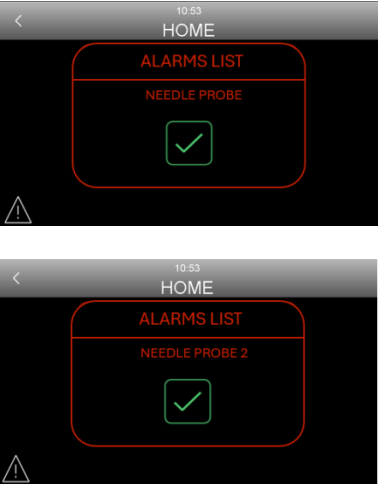
ALARM	DESCRIPTION
<p>11.3 THERMAL SWITCH ALARM</p> 	<p>The controller will activate a “THERMAL SWITCH” alarm if the safety thermostat (thermal switch) trips.</p> <p>This safety mechanism is designed to protect the oven and its components from damage in the event of a thermostat failure that causes the oven to overheat.</p> <p>Refer to SECTION 12: FAULT FINDING for troubleshooting guidance.</p> <div style="display: flex; align-items: center; margin-top: 20px;">  <p>WARNING: IF A THERMAL SWITCH ALARM IS ACTIVATED, THE CAUSE OF THE SAFETY STAT TRIP MUST BE IDENTIFIED AND RECTIFIED BEFORE RESETTING THE SAFETY STAT.</p> </div>
<p>11.4 CHAMBER HIGH TEMPERATURE ALARM</p> 	<p>If the chamber probe detects an oven temperature of 180 °C or higher, the controller will trigger a “CHAMBER HIGH TEMPERATURE” alarm.</p> <p>Refer to SECTION 12: FAULT FINDING for troubleshooting guidance.</p>
<p>11.5 HIGH BOARD TEMPERATURE ALARM</p> 	<p>The controller will trigger a “HIGH BOARD TEMPERATURE” alarm if the temperature of the main control board exceeds its safe threshold.</p> <p>While this alarm is active, it is not possible to start or continue a cooking cycle.</p> <p>Refer to SECTION 12: FAULT FINDING for troubleshooting guidance.</p>

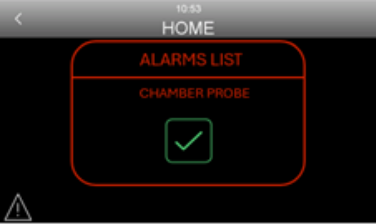
ALARM	DESCRIPTION
<p>11.6 MAIN CARD (CONTROL BOARD) COMMUNICATION ALARM</p> 	<p>The controller will trigger a “MAIN CARD COMMUNICATION” alarm if there is no data transfer or communication between the user interface and the control module. While this alarm is active, it is not possible to start a cooking cycle.</p> <p>Refer to SECTION 12: FAULT FINDING for troubleshooting guidance.</p>
<p>11.7 NEEDLE PROBE ALARM</p> 	<p>The controller will trigger a “NEEDLE PROBE” alarm if a fault is detected in Core Food Probe 1. Similarly, a “NEEDLE PROBE 2” alarm will be activated if a fault is detected in Core Food Probe 2.</p> <p>While either of these alarms is active, it is not possible to start or continue a cooking cycle using the affected probe or the Delta T function.</p> <p>To determine how the controller designates Probe 1 and Probe 2, refer to Section 4.15.</p> <p>Note: After a probe is connected to the oven, the controller may require up to one minute to detect the probe and allow its temperature readings to stabilize. If the cooking cycle is started immediately after connecting the probes, the controller may generate an alarm indicating that the probes are not connected.</p> <p>If an alarm persists, Refer to SECTION 12: FAULT FINDING for troubleshooting guidance.</p>

ALARM	DESCRIPTION
<p>11.8 CHAMBER PROBE ALARM</p> 	<p>The controller will trigger a “CHAMBER PROBE” alarm if a fault is detected in the operating thermostat.</p> <p>While this alarm is active, it is not possible to start or continue a cooking cycle.</p> <p>Refer to SECTION 12: FAULT FINDING for troubleshooting guidance.</p>
<p>11.9 POWER CARD/CONTROL MODULE COMPATIBILITY</p> 	<p>The controller will trigger a “POWER CARD COMPATIBILITY” alarm if the user interface and control module are running different firmware versions.</p> <p>It is highly unlikely for this alarm to occur, as the appliance undergoes full testing prior to shipment. If the issue arises, it can be resolved by updating to the latest firmware version.</p>
<p>11.10 POWER CONSUMPTION ALARM</p> 	<p>When the unit is equipped with an Energy Optimization System (EOS) e.g. Sicotronic System, the controller may trigger a Power Consumption alarm. This occurs when multiple appliances operate simultaneously, and the EOS prioritizes and adjusts energy distribution to prevent system overload.</p> <p>This alarm does not indicate a fault. It is a normal function of the EOS, designed to optimize energy usage by temporarily limiting power to certain appliances, helping to reduce peak energy consumption and prevent potential overloads.</p> <p>While this alarm is active, the heating elements will be switched off.</p> <p>If the alarm persistent, Refer to SECTION 12: FAULT FINDING for troubleshooting guidance.</p>

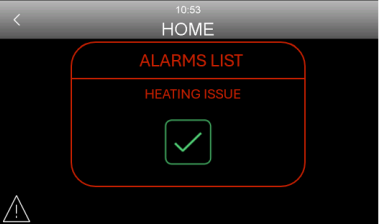
ALARM	DESCRIPTION
<p>11.11 HEATING ISSUE ALARM</p> 	<p>If the oven does not begin heating during the preheat cycle, or if the temperature increases more slowly than expected, the control system will generate a “HEATING ISSUE” alarm.</p> <p>Refer to SECTION 12: FAULT FINDING for troubleshooting guidance.</p>

12.0 FAULT DIAGNOSTIC & RECTIFICATION

12.1 THERMAL SWITCH (SAFETY STAT) ALARM

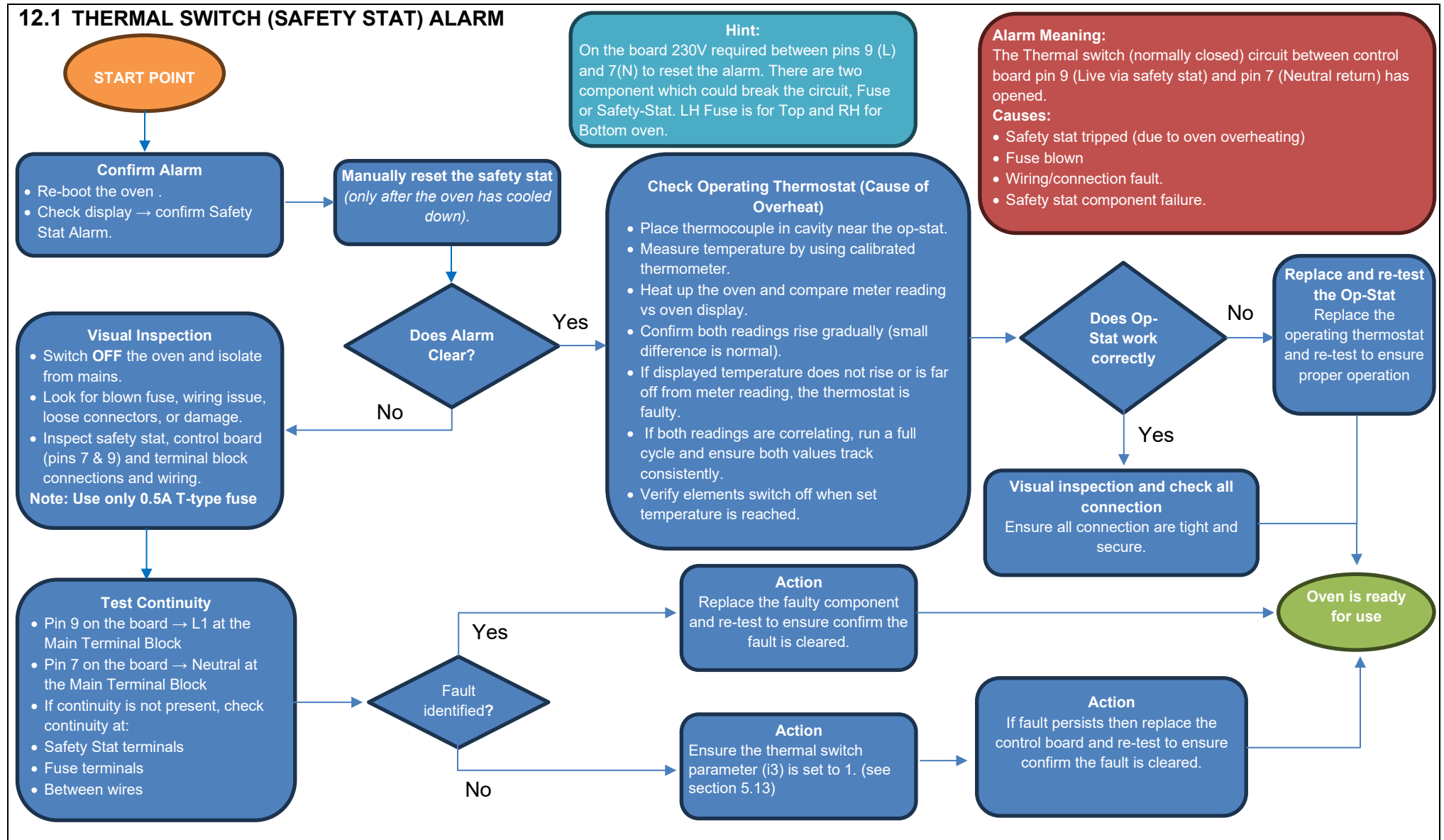

12.2 OVEN DOOR ALARM

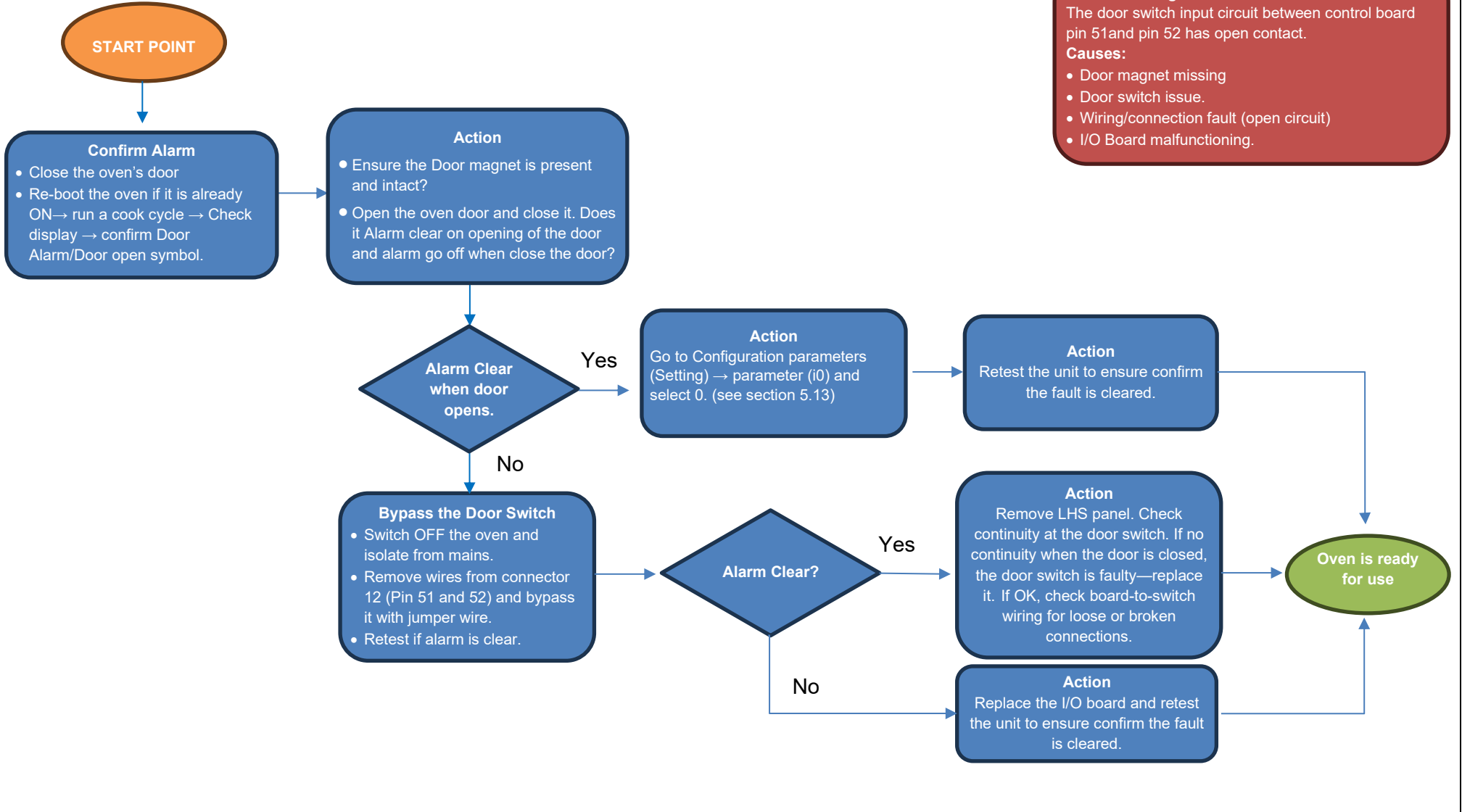

12.3 CHAMBER HIGH TEMPERATURE ALARM

Hint:

- Configuration parameter (A1) set value is not correct.
- Chamber probe (Op-Stat) reading false reading.
- Configuration parameter (r0) set value is not correct.
- Configuration parameter (r2) set value is not correct.

Alarm Meaning:

High temperature alarm activates if the chamber probe detects oven temperature above 180 °C, or if the chamber probe (op-stat) is faulty or not properly connected.

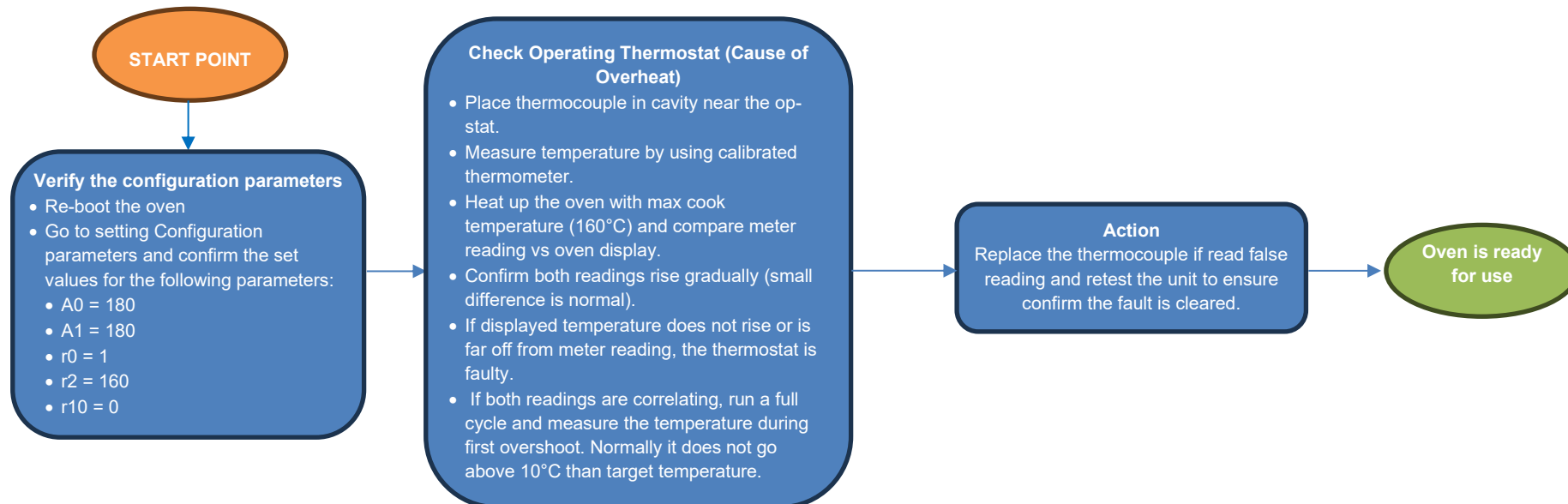

12.4 HIGH BOARD TEMPERATURE ALARM

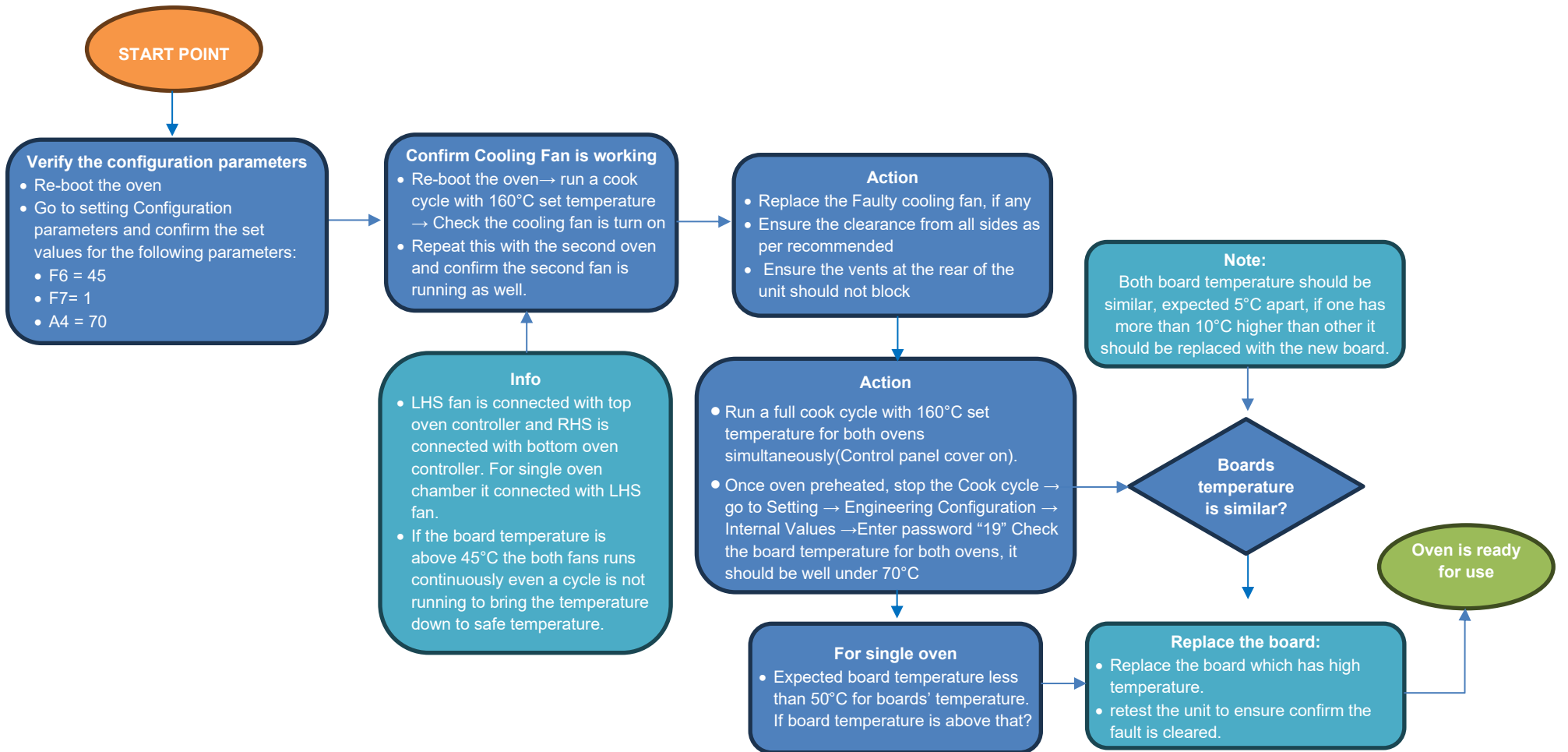

12.5 MAIN CARD (CONTROL BOARD) COMMUNICATION ALARM

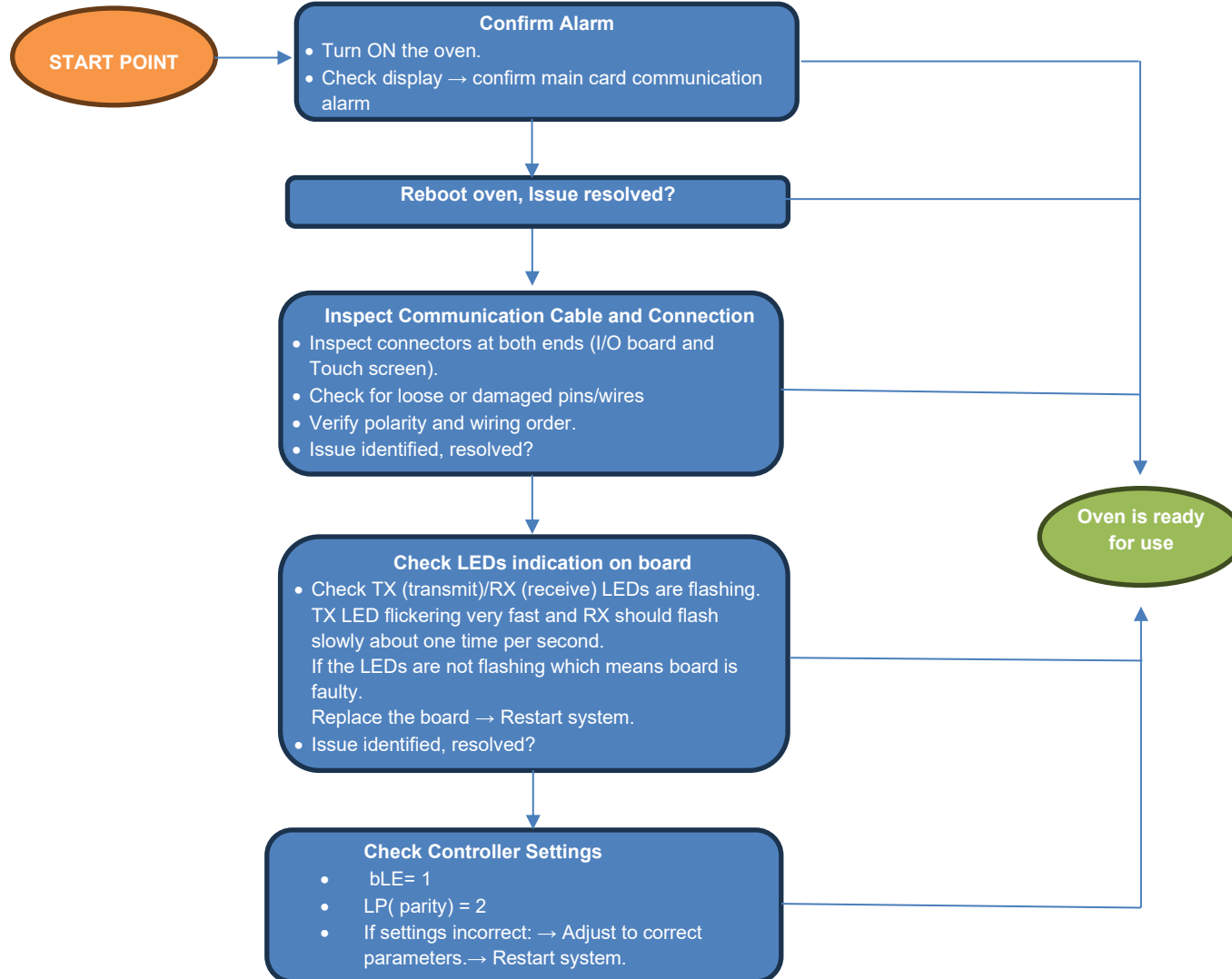

12.6 CORE (NEEDLE) PROBE ALARM

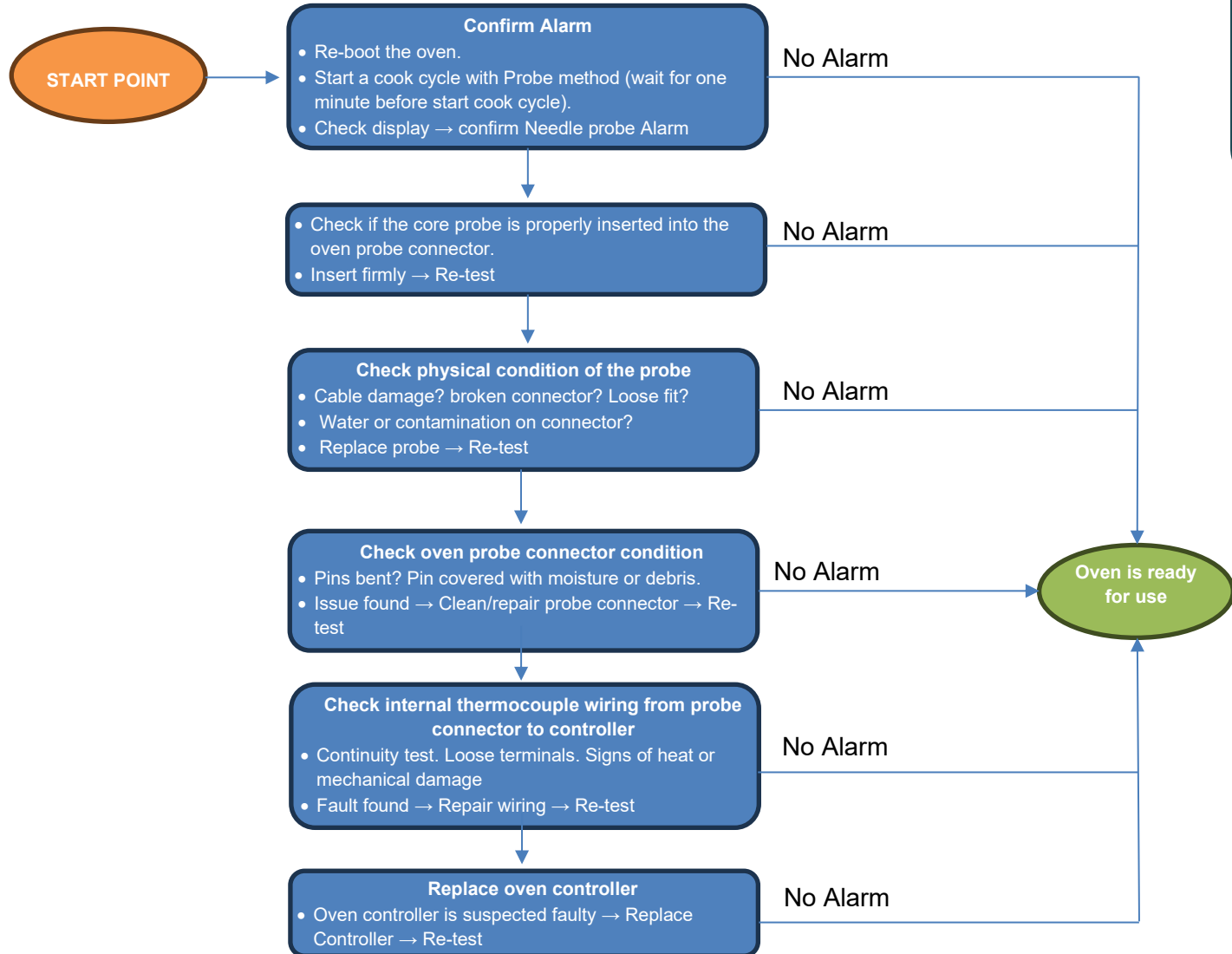

Hint:

- When both probes are connected, the controller will assign Core Probe 1: LHS, Core Probe 2 RHS.
- If one probe is connected before the cycle begins and the second probe is connected after, the controller will assign the first probe as Core Probe 1 and the second probe as Core Probe 2.

12.7 CHAMBER PROBE (OPERATING THERMOSTAT) ALARM

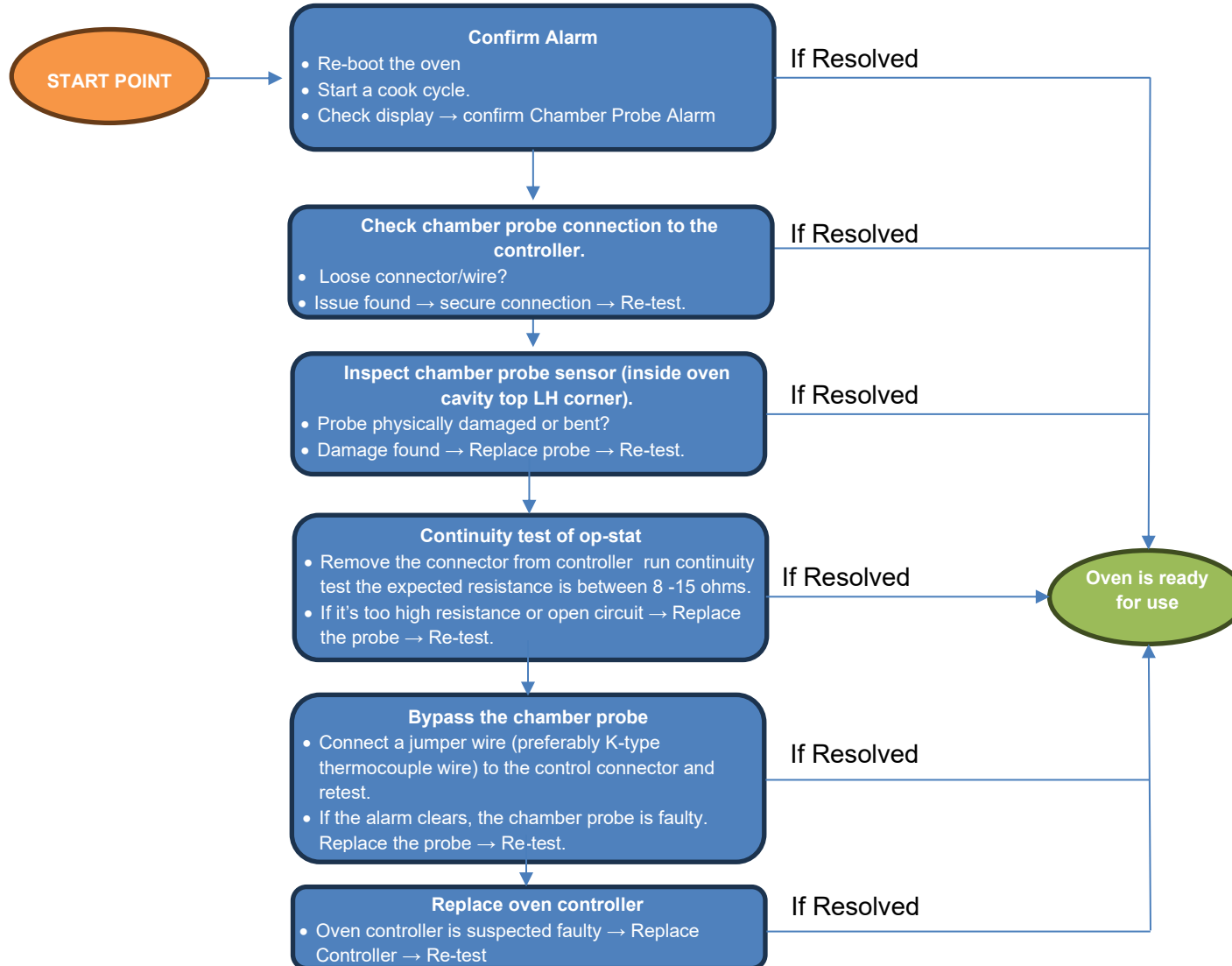

12.8 HEATING ISSUE ALARM / NO HEATING OR SLOW HEATING

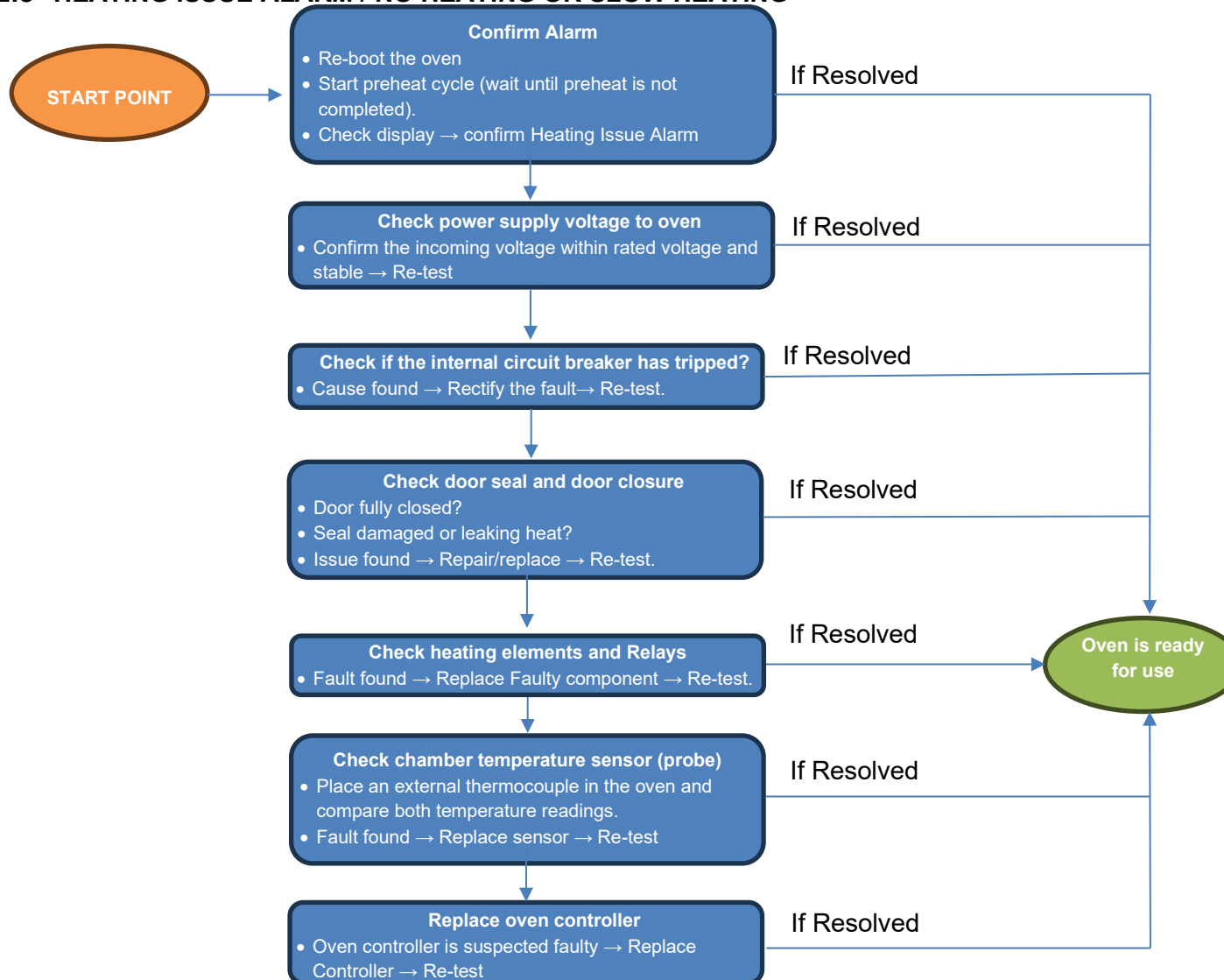

Hint:

- Heating issue alarm raised if the temperature rise is not within the expected rate during preheat.
- Issue could be with thermostat, Heating elements or supply voltage.
- If the same heating issue with both ovens, then most likely it would be supplying voltage issue.

Oven Heating Element Circuit Test – Quick Guide
 Heater Elements: Two heating circuit-Standard Heater and Booster Heater

- **SSR (Standard):** 40.7 Ω, 5.65 A @ 230 V
- **EM Relay (Booster):** 44 Ω, 5.22 A @ 230 V

Tolerance: Small deviations acceptable.
 If the Standard or booster heater resistance is out of limits.

1. Top Oven / Single Oven
SSR Circuit:

- **LHS Element:** Disconnect wire **51** → measure to N → 151 Ω
- **RHS Element:** Disconnect wire **55** → measure to N → 151 Ω
- **Base Element:** Disconnect wire **59** → measure to N → 88 Ω

EM Circuit:

- **LHS Element:** Disconnect wire **53** → measure to N → 88 Ω
- **RHS Element:** Disconnect wire **57** → measure to N → 88 Ω

2. Bottom Oven
SSR Wires: 61 (LHS), 65 (RHS), 69 (Base)
EM Wires: 63 (LHS), 67 (RHS)
 Procedure: Same as top oven. Disconnect wire → measure to N → verify resistance.
Tip: Power off oven before testing; use a calibrated multi-meter.

12.9 TOUCH SCREEN NOT TURNING ON

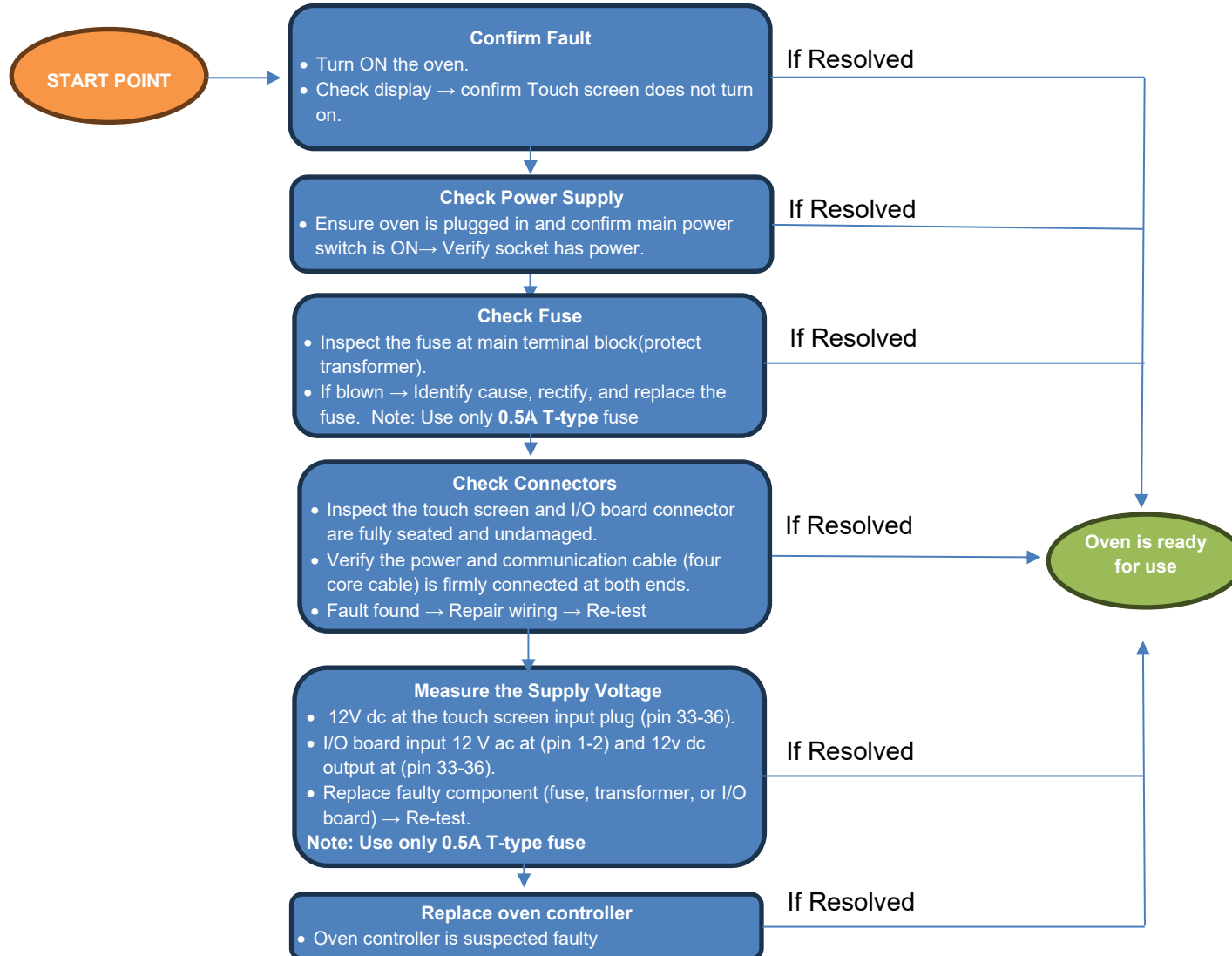

13.0 SPARE PARTS

Consult the Spare Parts Manual (T102001) for information on replacement components.

When ordering spare parts, please quote the following:

Model Number

Serial number

This information will be found on the data plate attached to the appliance.

Visit our website for further spares information.

14.0 SERVICE INFORMATION

This unit carries an extensive mainland UK warranty. The warranty is in addition to and does not change your statutory or legal rights.

The warranty policy can be found on our website which details the conditions of the warranty and the exclusions.

<https://www.falconfoodservice.com/info-centre/policy>



Service calls to equipment under warranty will be carried out in accordance with the conditions of sale.

Warranty calls can be made between 8:30 am and 5:00 pm on weekdays only.

To ensure your warranty enquiry is handled as efficiently as possible, ensure you have the following appliance information prior to calling us:

1. Model number – found on the data plate
2. Serial number – found on data plate
3. Brief description of the issue

To contact Falcon for a warranty issue dial (UK only) 01786 455 200 and select Warranty Issues from the menu.